



Automotive

## Battery Management System (BMS)

# Contents

1. Introduction	3
<hr/>	
2. Application description	4
2.1 Battery pack designs	4
2.2 Functions of the BMS	5
<hr/>	
3. Block Diagram	7
A Cell balancing	7
B Cell monitoring	8
C Module and Pack Management Unit (MMU, PMU)	9
D Communication interface	9
E Power supply and management	10
F Charge/discharge control	10
<hr/>	
4. Design challenges and Nexperia solutions	11
4.1 Achieving precise and reliable cell balancing in high-current battery Modules	11
4.2 Maintaining a safe operating envelope of the battery pack	13
4.3 Achieving reliable contactor control to connect and disconnect the battery pack to various loads	15
4.4 Approach for powering auxiliary circuits	19
4.5 What strategies protect sensitive BMS circuitry from voltage transients and surges?	21
4.6 Reliable logic level shifting between BMS integrated circuits operating at different voltage domains	22
<hr/>	
5. Recommended products	25
<hr/>	
6. References	26
<hr/>	

# 1. Introduction

As electric and hybrid vehicles continue to evolve across all voltage classes, from 48 V mild hybrids to 800 V high-performance BEVs, the role of Battery Management Systems (BMS) has become increasingly critical. BMS solutions are the cornerstone of safe, efficient, and intelligent operation of battery systems, ensuring optimal battery performance, longevity, and safety under diverse operating conditions.

Automotive BMS addresses a wide spectrum of challenges, including:

- › Accurate state estimation of battery parameters such as State of Charge (SoC), State of Health (SoH), and State of Power (SoP)
- › Thermal management across densely packed cells in high-voltage battery packs
- › Cell monitoring and balancing to prevent degradation and ensure uniform performance
- › Fault detection and isolation to protect against overvoltage, undervoltage, overcurrent, and thermal runaway

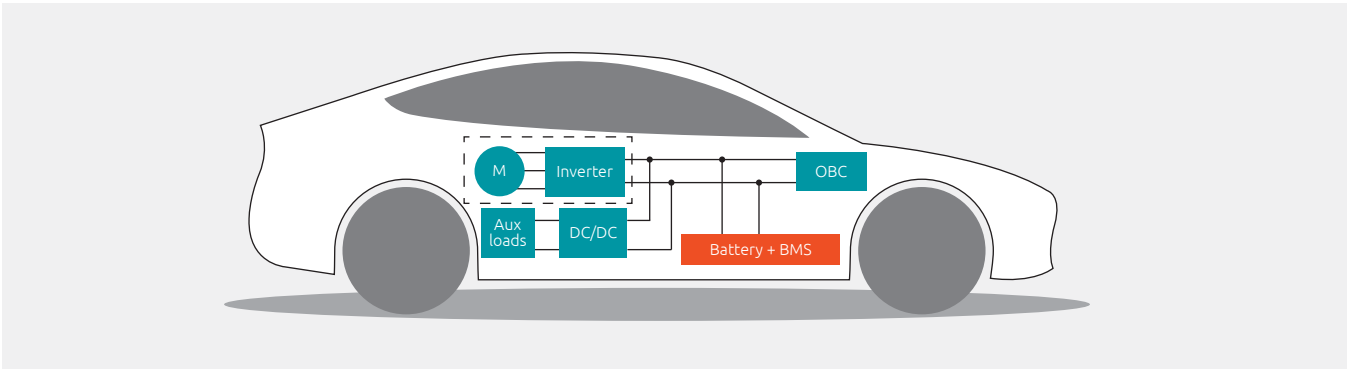


Fig 1. Illustrative image of an EV power architecture with the BMS central to the battery functions

In Electric Vehicles (EVs), BMS must interface seamlessly with fast-charging systems, including bidirectional OBCs, enabling advanced functionalities such as Vehicle-to-Grid (V2G) and Vehicle-to-Load (V2L). For hybrid vehicles, BMS solutions must coordinate energy flow between internal combustion engines, regenerative braking systems, and auxiliary loads, often under rapidly changing conditions.

According to industry trends, the global EV market is expected to continue its rapid expansion, with significant growth in both passenger and commercial vehicle segments. This growth is supported by advancements in battery technology, charging infrastructure, and vehicle electronics. However, the increasing complexity of battery systems, including higher voltages, greater energy densities, and more sophisticated safety requirements poses significant challenges for **BMS designers**.

Nexperia's commitment to innovation is evident in its ongoing investments in research and development, as well as its focus on sustainability and environmental responsibility. Nexperia's product portfolio is continuously expanded to address the latest market trends, including the transition to wide-bandgap semiconductors, energy harvesting, and advanced power management solutions.

Nexperia's solutions align with these trends by offering:

- › Low-power logic ICs and power supply ICs for energy-efficient control
- › Both low voltage silicon and high-voltage SiC MOSFETs to cover all battery systems (up to 800 V)
- › Automotive-grade protection devices for enhanced system safety
- › Bipolar discrete devices for control systems integrations and communication optimization

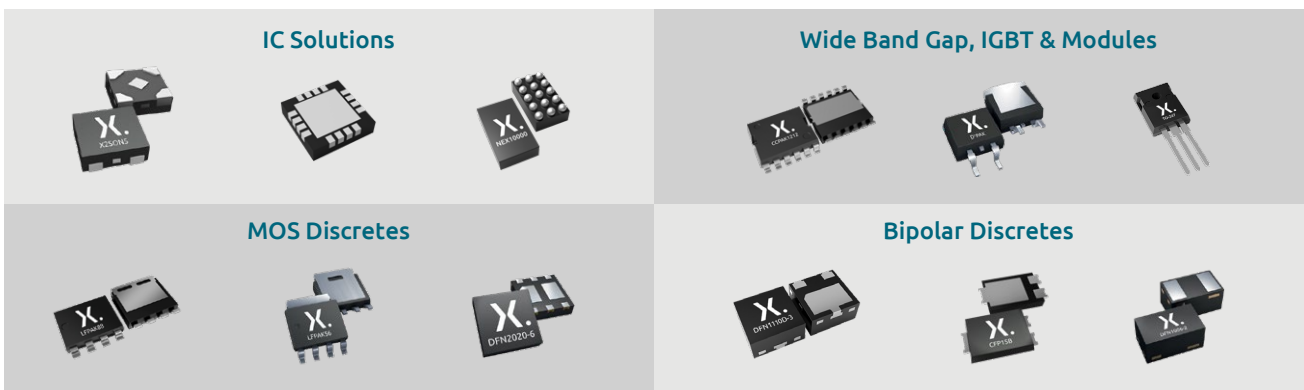


Fig 2. Nexperia product families are continuously expanding

## 2. Application description

### 2.1 Battery pack designs

Automotive battery packs are built from individual cells, which are grouped into modules, and then assembled into a complete pack as illustrated in Figure 3.

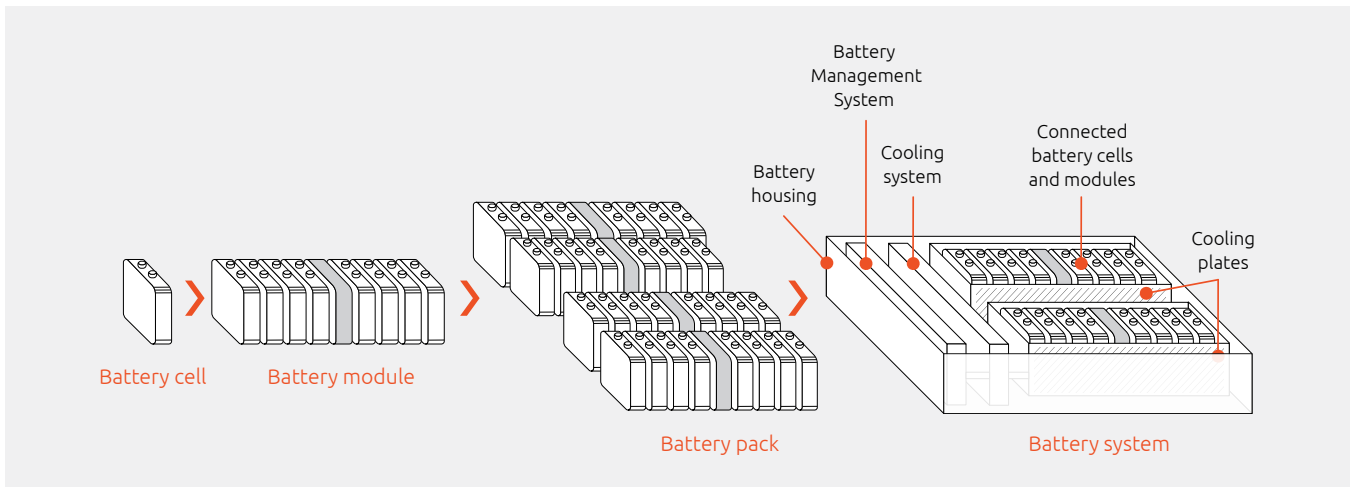


Fig 3. Cell to module to pack hierarchy allows scalability in voltage and capacity

There are three main types of battery cells used in EVs: cylindrical, prismatic and pouch cells.


Shape	Cylindrical cells	Prismatic cells	Pouch cells
			
	Tube-like – similar to AA batteries	Rectangular box	Flat, flexible foil packaging

Table 1. Types of cells used in automotive battery systems

These types of cells can be made in different chemistries; two main ones are LFP (Lithium Iron Phosphate) and NMC (Nickel Manganese Cobalt). LFP cells typically have a lower nominal voltage (~3.2V per cell) compared to NMC (~3.7V per cell). LFP and NMC cells have different properties, summarized in the Table 2 below.

Characteristics	Lithium Iron Phosphate (LFP)	Nickel Manganese Cobalt Oxide (NMC)
Energy density	90-120 Wh/kg	100-265 Wh/kg
Power density	1800-500 W/kg	250-340 Wh/kg
Advantages	Long cycle life, lower cost	Higher energy density
Disadvantages	Lower Energy Density	Higher cost, lower thermal stability

Table 2. Differences between LFP and NMC cell chemistries

A series combination of the cells increases module voltage; parallel combination of the cells improves module power capacity. For example, if 10 cells with nominal voltage of 3.2 V and 10 Ah capacity are arranged in series, total output voltage will be 32 V and total capacity remain as a single cell which is 10 Ah. If the same cells are now arranged in parallel with additional 10-cell paralleled, the configuration is known as 10s2p meaning 10 cells in series and 2 in parallel. The output voltage will be 32 V and the capacity will double to 20 Ah.

Since cells are arranged into modules, the modules are then combined in series configuration to form a high voltage battery pack.

- › Module voltages are typically 48 V to 120 V and pack voltage varies by designs. Typical pack voltages vary by applications and classes, 48 V for mild hybrids (1 module), 400 V for standard BEVs and PHEVs, 800 V for high-performance and commercial EVs.
- › Series combination of modules increases pack voltage, parallel combination improves pack energy capacity (Wh).

The battery pack interfaces with the vehicle's powertrain, charging system, and onboard electronics, requiring the BMS to monitor and control all aspects of battery operation within safe conditions.

## 2.2 Functions of the BMS

The BMS is responsible for ensuring safe and efficient operation of the battery pack by performing the following functions:



### Monitoring

Continuously measures cell voltages, temperatures, and currents to detect anomalies and preventing potentially hazardous situations. By constantly analysing these data points, the BMS can identify issues such as overcharging, over-discharging, overheating, or short circuits before they escalate into safety risks or cause permanent damage to the battery.



### Cell Balancing

Some cells may become overcharged or over-discharged while others remain underutilized, leading to reduced overall battery performance and shortened lifespan. Cell balancing addresses these natural variations by dissipating excess energy from higher-voltage cells through resistors (Passive) or by transferring energy from higher-voltage cells to lower-voltage (Active).



### Protection

Algorithms are used to calculate State of Charge (SoC), State of Health (SoH), and State of Power (SoP). The BMS plays a vital role in protecting the battery system through a suite of safety mechanisms. These protections are designed to intervene automatically when unsafe conditions are detected, such as by disconnecting the battery pack from the vehicle's electrical system or reducing the current flow to prevent further stress on the cells. Such interventions are crucial for maintaining the integrity of the battery and safeguarding both the vehicle and its occupants.



### Communication

The BMS interfaces with vehicle ECUs, charging systems, and thermal management units via CAN, LIN, or ISO 15118 protocols. Through these networks, the BMS shares critical information including SoC, SoH, and temperature data. Fault and warning signals, charging/discharging permissions and limits are communicated externally, requests for thermal management (e.g., activating battery cooling or heating) are communicated through the BMS.

## BMS Architectures

BMS architectures vary depending on the application's requirements. The three main types are Centralized, Distributed, and Modular, each suited to different applications based on complexity, scalability, and cost. Here's a breakdown of the three key BMS architectures used in EVs.

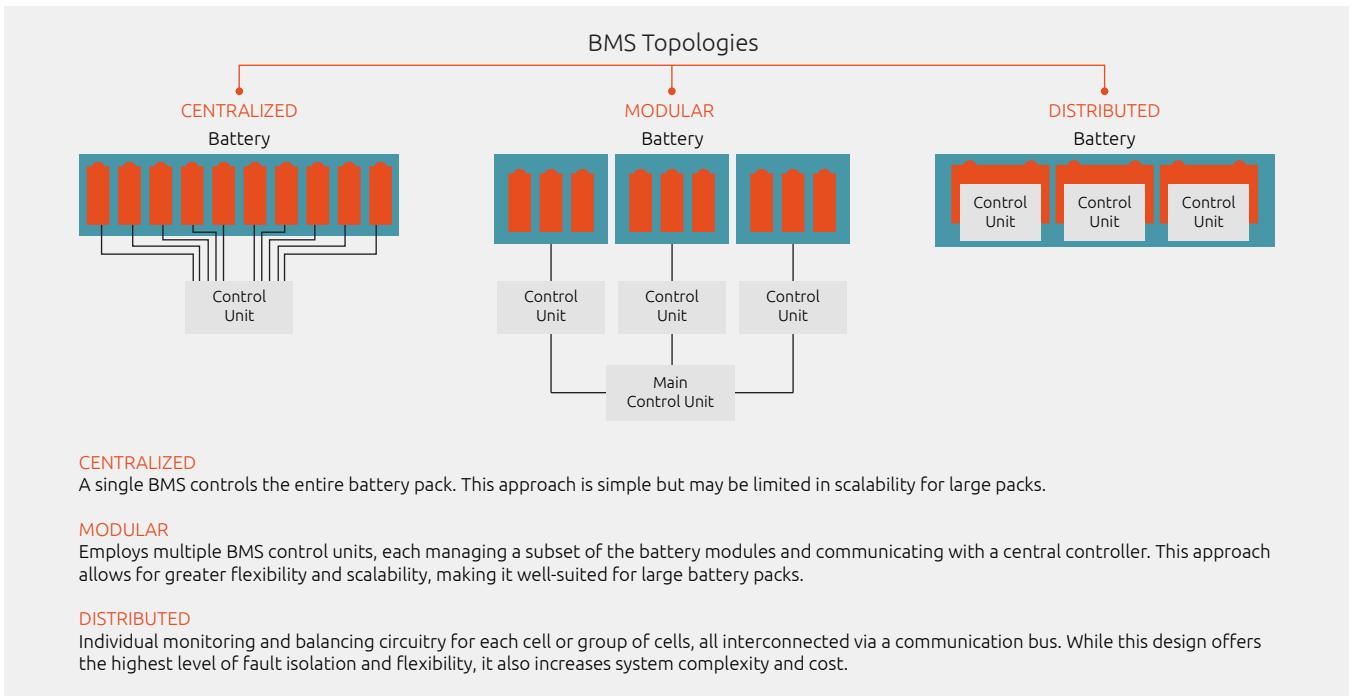


Fig 5. Battery architectures commonly used in automotive battery systems

The BMS architecture can be configured to meet a wide range of application needs as shown in Figure 6.





	E Scooters/Bikes	Hybrids (MHEV/HEV/PHEV)	Battery EVs (BEV)	E-buses/trucks
Typical voltage range	 24 V - 72 V	 48 V - 300 V	 200 V - 800 V	 600 V - 1100 + V
<b>BMS Architecture (Preferred)</b>	Centralised - low cell counts systems	Modular - smaller battery packs, integration with ICE systems	Modular or distributed larger battery packs, balance of scalability high-power demand	Distributed - high voltage battery packs, large cells count

Fig 6. Typical BMS architectures in automotive mobility systems

Overall, the BMS is a highly adaptable and critical component of modern battery systems, capable of supporting a wide range of architectures, balancing techniques, and communication protocols to meet the diverse needs of automotive and industrial applications. By leveraging advanced semiconductor solutions from companies like Nexperia, engineers can design BMS systems that are not only robust and reliable but also scalable and efficient, ensuring optimal performance and longevity for battery packs in even the most demanding environments.

### 3. Block diagram

Below is a functional block diagram of a modular BMS for an automotive battery pack with products available from Nexperia Catalogue. All products currently offered by Nexperia for the BMS application are Automotive grade qualified.

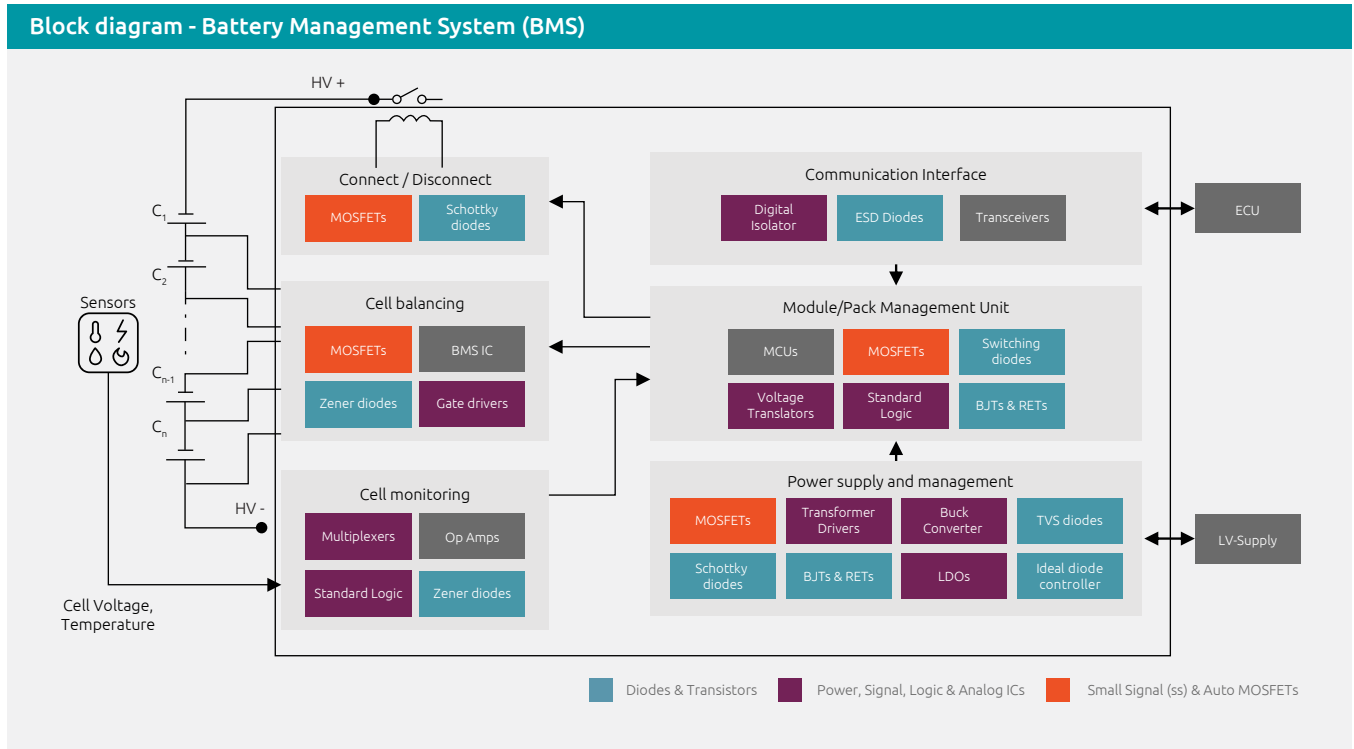


Fig 7. BMS block diagram

### A. Cell balancing

Cell balancing is a functionality that ensures that all cells in a pack maintain similar voltage levels, which is critical for safety, performance, and longevity. Imbalanced cells can lead to reduced capacity, overheating, or failure. Cell balancing stages corrects this by using either one of the methods described below, which are Passive cell balancing or Active cell balancing.

#### Passive cell balancing

This method takes excess energy from voltage cells and dissipates it as heat through resistor. It allows for low cost and simple design, but the cons are that energy is dissipated as heat which is wasteful for efficiency operation of the battery packs.

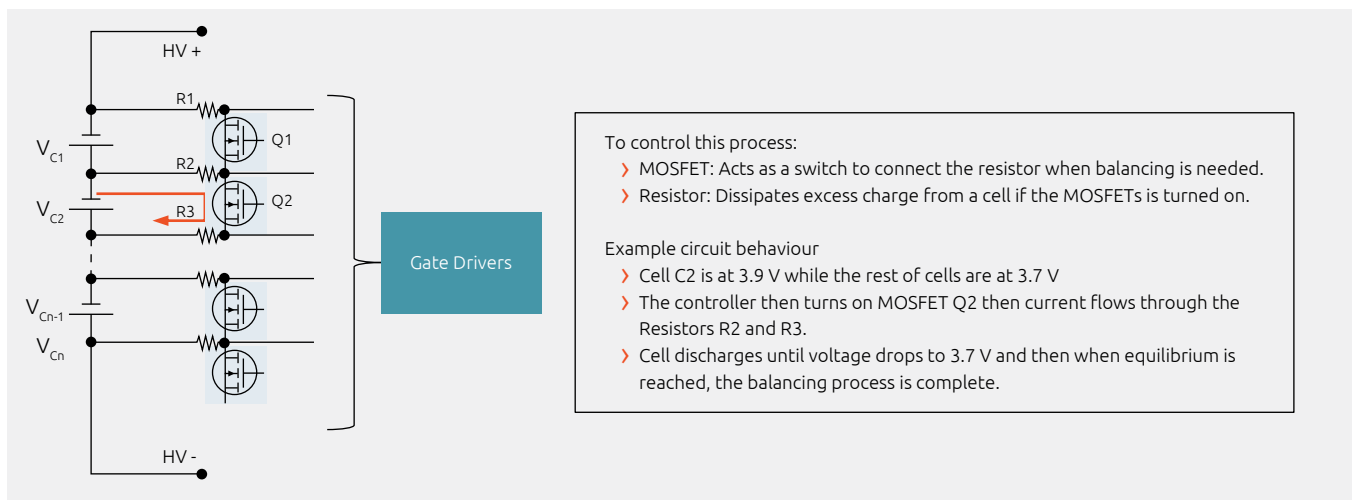


Fig 8. Passive cell balancing circuit

## Active cell balancing

This method works by transferring excess energy from higher-voltage cells to lower voltage ones using various techniques. Some common techniques include capacitive balancing, inductive balancing and DC-DC Converter balancing techniques. These methods are more complex to implement but it conserves energy and is suitable for larger high voltage battery packs. An example is shown below using bidirectional flyback converters.

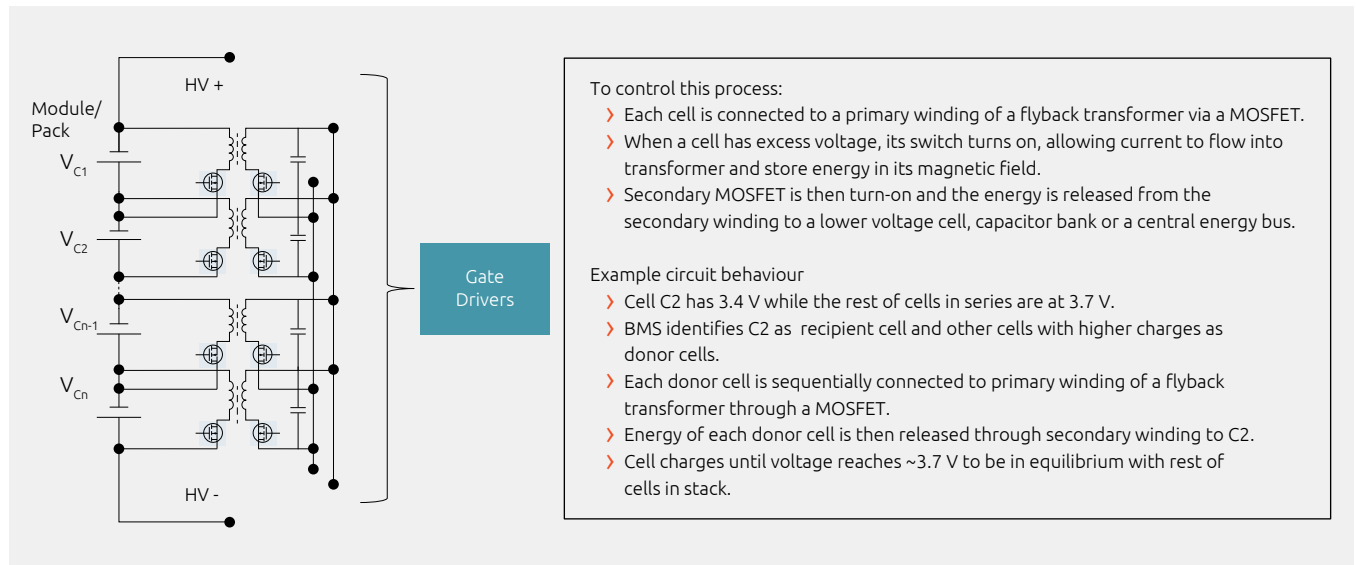


Fig 9. Active cell balancing circuit example

## B. Cell monitoring

Cell monitoring functionality in the block diagram is to perform continuous measurement and tracking of individual battery cell parameters to ensure safe, efficient, and balanced operation of the entire battery pack. Measurements include voltages to monitor overvoltage or undervoltage conditions of individual cells, temperature state to prevent thermal runaway and current to detect short circuits and estimate the state of charge.

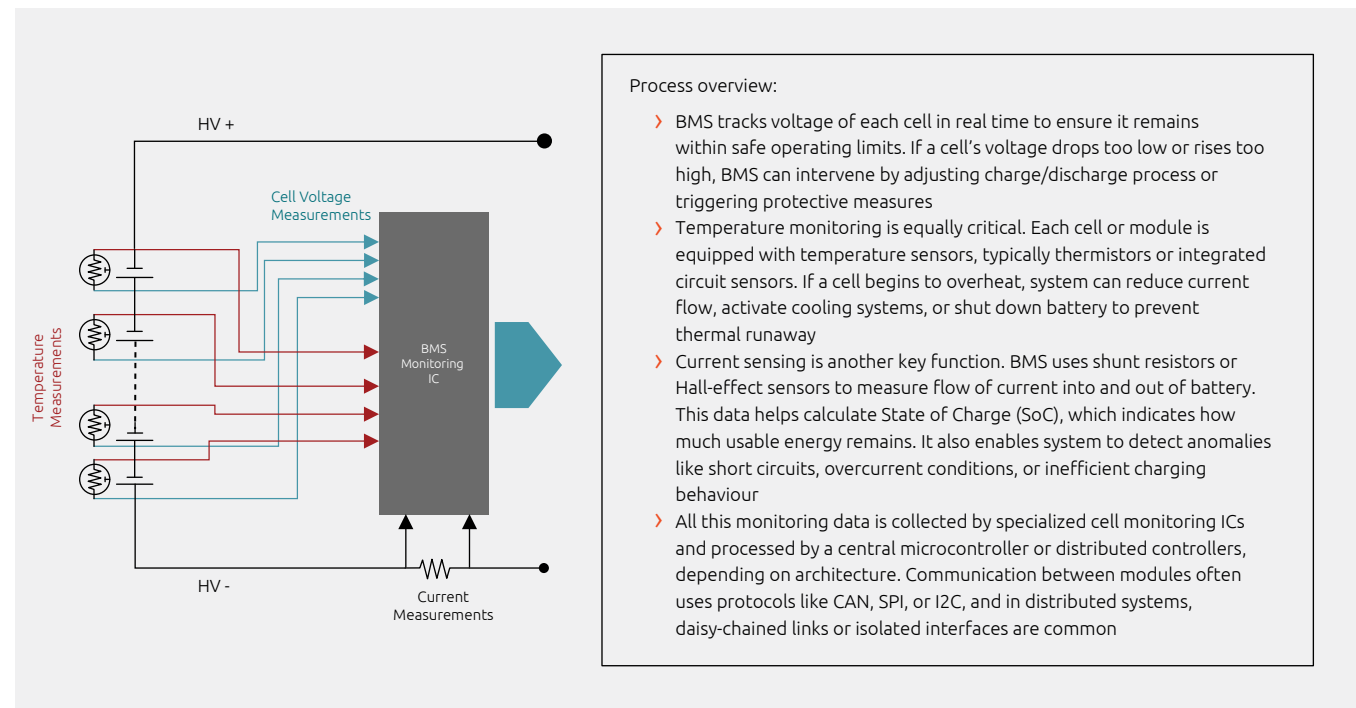


Fig 10. Typical architecture of cell monitoring in a BMS

## C. Module and Pack Management Unit (MMU, PMU)

While cell monitoring circuits focus on voltage, temperature, and balancing at the cell level, the PMU integrates this data to manage the entire module or pack as a cohesive unit. The PMU typically resides at the top of the BMS hierarchy and interfaces with multiple Module Management Units (MMUs). It aggregates data from each cell or module, processes it, and makes decisions about charging, discharging, fault detection, and thermal management. This centralized control enables the BMS to maintain pack-level safety and performance, even when individual cells behave differently due to aging or environmental factors.

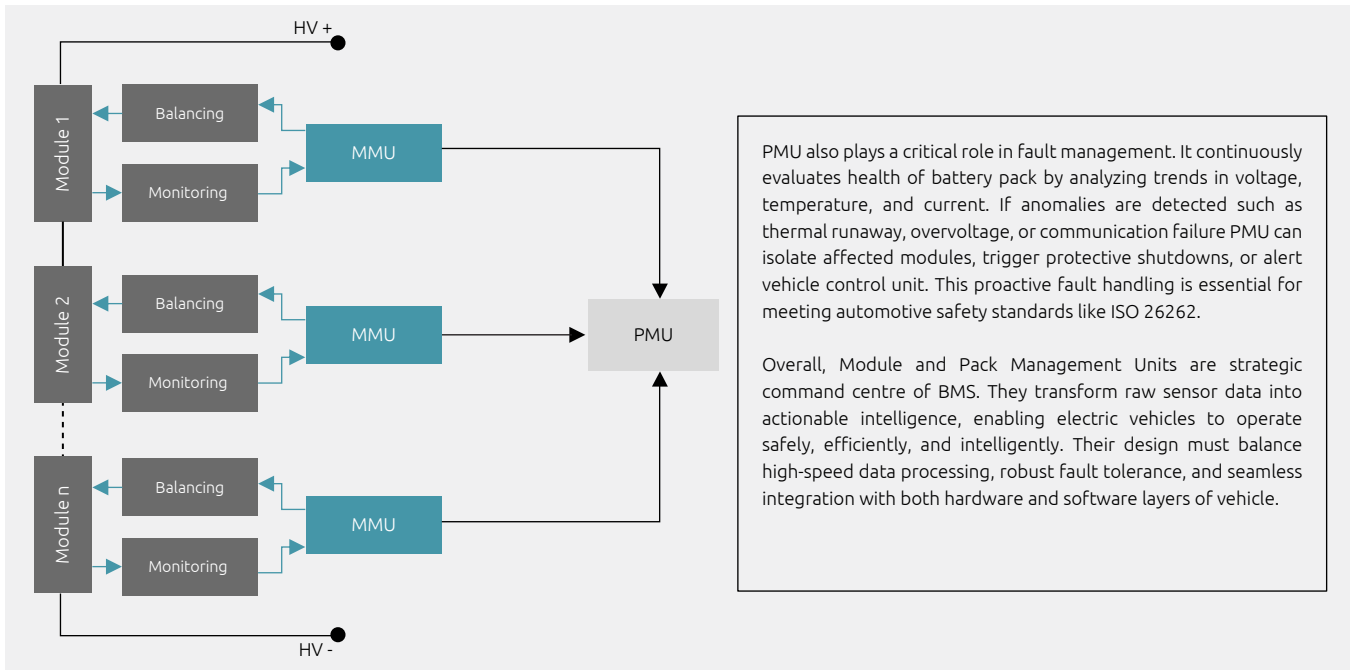


Fig 11. Illustration of module and pack management units

## D. Communication interface

Communication interface enable seamless data exchange between various components such MMUs, PMUs and the vehicle's central control system. These interfaces ensure that real-time information about voltage, temperature, current, and fault conditions is accurately transmitted and acted upon, which is essential for maintaining battery safety, performance, and longevity.

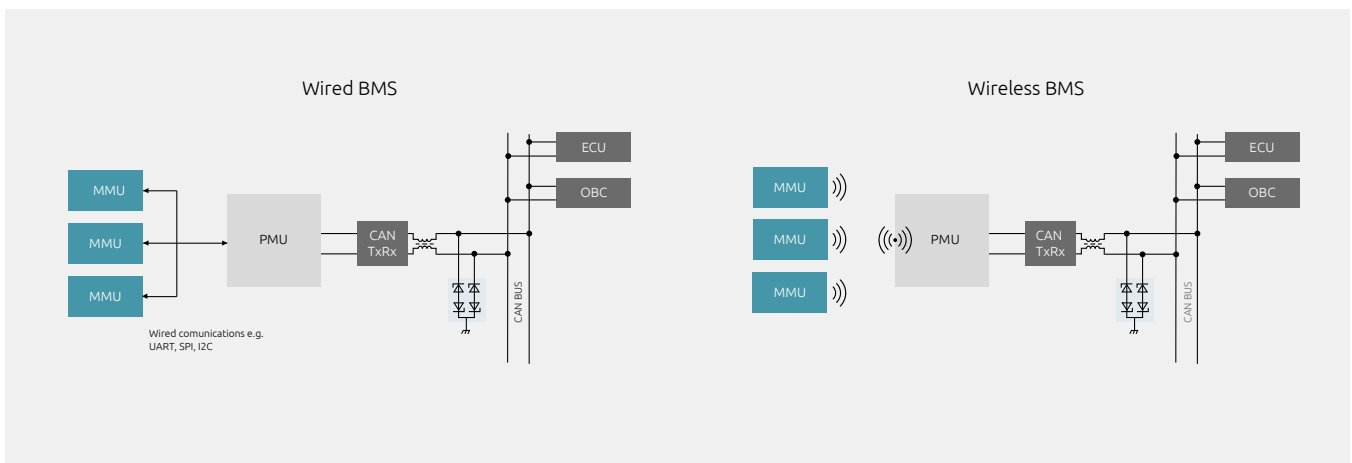


Fig 12. Communication interfaces between MMUs and PMUs can either be wired or wireless

Between the MMU and the PMU, wired serial protocols like SPI (Serial Peripheral Interface) and I<sup>2</sup>C (Inter-Integrated Circuit) are commonly used. In distributed BMS architectures, daisy-chained SPI links allow multiple monitoring chips to be connected across modules, enabling scalable and synchronized data collection. In addition to traditional wired interfaces, modern BMS designs are increasingly adopting wireless communication, known as wireless BMS (wBMS). This approach eliminates the need for physical wiring between MMUs and PMUs, reducing weight, complexity, and assembly time. Wireless BMS typically uses protocols like Bluetooth Low Energy (BLE), Zigbee, or proprietary RF solutions to transmit data securely and reliably.

For higher-level communication between the BMS and the vehicle's Electronic Control Unit (ECU), the most widely adopted protocol is CAN bus (Controller Area Network). It allows the BMS to report critical parameters such as State of Charge (SoC), State of Health (SoH), fault codes, and thermal status to the vehicle's dashboard and control systems.

## E. Power supply and management

The BMS must remain operational even when the vehicle is off, during sleep modes, or under fault conditions, which makes low-power design a critical aspect of its architecture. The BMS typically draws power from the battery pack itself, but it must regulate and distribute this power across multiple subsystems such as cell monitoring ICs, microcontrollers, communication interfaces, cell balancing circuits, and protection devices. To achieve this, designers use a combination of buck converters, low-dropout regulators (LDOs), and isolated DC-DC converters to step down high pack voltages (e.g., 400V or 800V) to safe operating levels like 12V, 5V, or 3.3V. These regulators must be automotive grade, with high efficiency and low quiescent current to minimize parasitic drain.

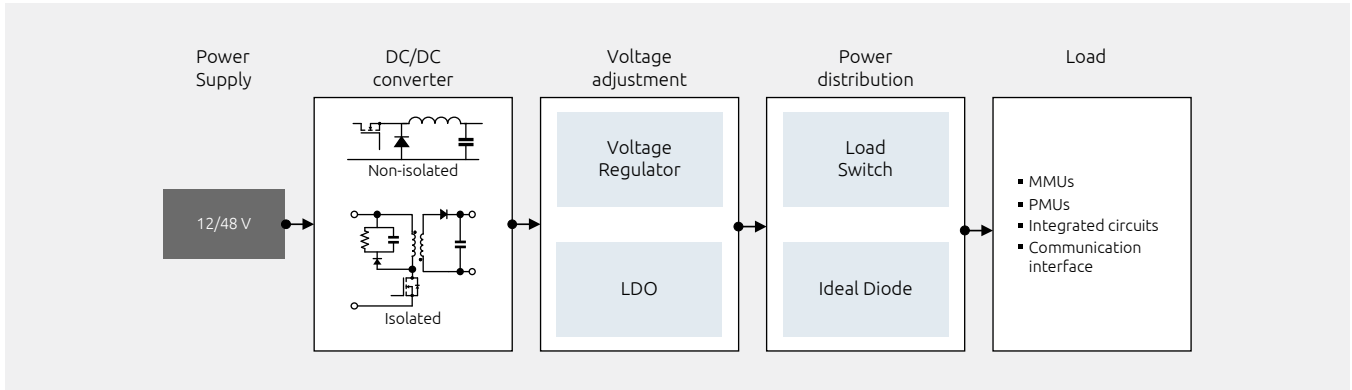
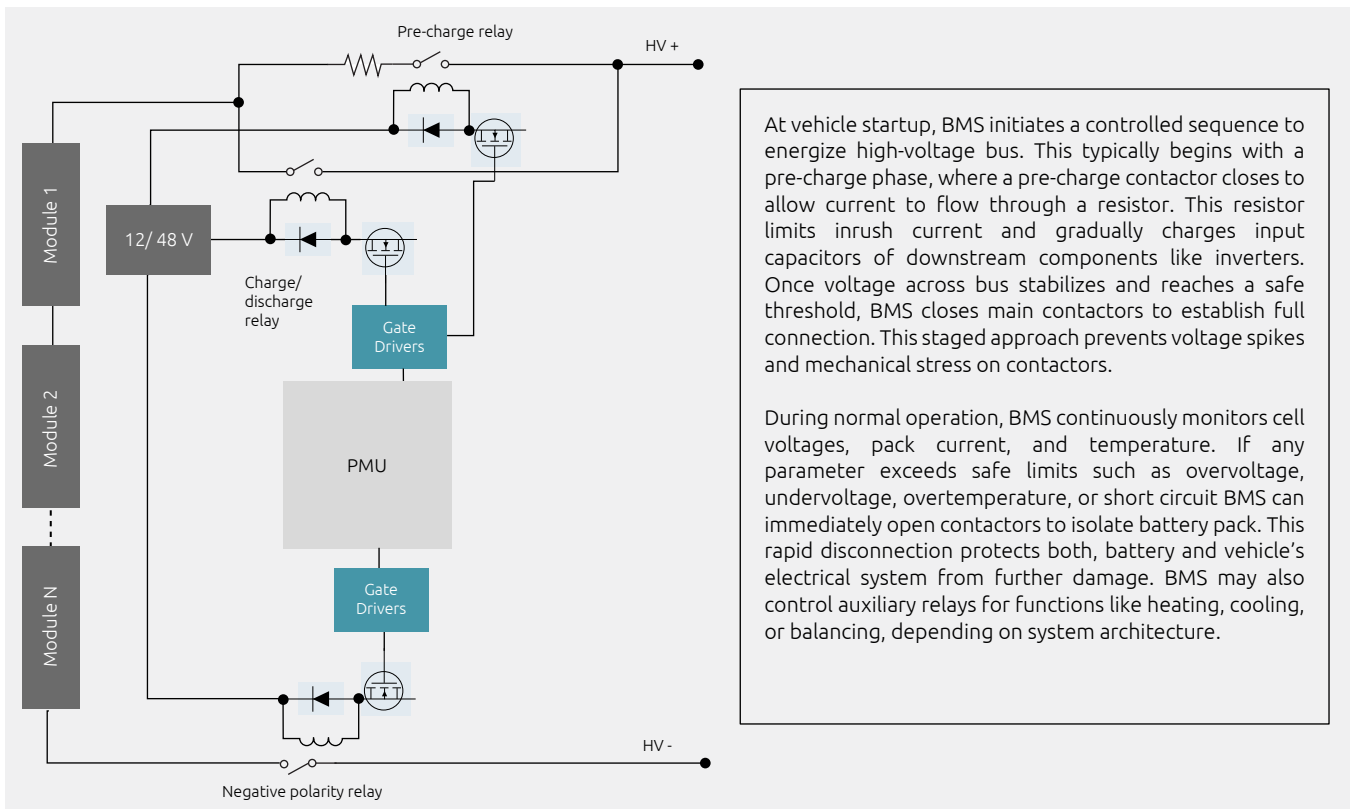


Fig 13. Power management sub-block diagram

## F. Charge/discharge control

The BMS controls a series of high-voltage relays or contactors that manage the safe connection and disconnection of the battery pack from the rest of the vehicle's high-voltage system. The contactors act as heavy-duty relays, enabling or cutting off power flow to traction inverters, chargers, and auxiliary systems depending on the state of the vehicle and detected safety conditions.



At vehicle startup, BMS initiates a controlled sequence to energize high-voltage bus. This typically begins with a pre-charge phase, where a pre-charge contactor closes to allow current to flow through a resistor. This resistor limits inrush current and gradually charges input capacitors of downstream components like inverters. Once voltage across bus stabilizes and reaches a safe threshold, BMS closes main contactors to establish full connection. This staged approach prevents voltage spikes and mechanical stress on contactors.

During normal operation, BMS continuously monitors cell voltages, pack current, and temperature. If any parameter exceeds safe limits such as overvoltage, undervoltage, overtemperature, or short circuit BMS can immediately open contactors to isolate battery pack. This rapid disconnection protects both, battery and vehicle's electrical system from further damage. BMS may also control auxiliary relays for functions like heating, cooling, or balancing, depending on system architecture.

Fig 14. Relays for pre-charge and charge/discharge in both positive and negative polarities

## 4. Design challenges and Nexperia solutions

Designing a robust and efficient Battery Management System (BMS) for automotive applications presents numerous technical hurdles. Addressing these challenges is crucial for ensuring safety, reliability, efficiency, and optimal battery life. This section explores key design challenges in detail and highlights how Nexperia's semiconductor solutions help engineers overcome them.

### 4.1 Achieving precise and reliable cell balancing in high-current battery modules

Cell balancing is essential to maintain uniform State of Charge (SoC) across all cells. Due to manufacturing tolerances, temperature gradients, and aging effects, individual cells in a series-connected pack tend to drift apart in voltage and capacity over time. Without balancing, weaker cells limit the performance, safety, and lifespan of the entire pack.

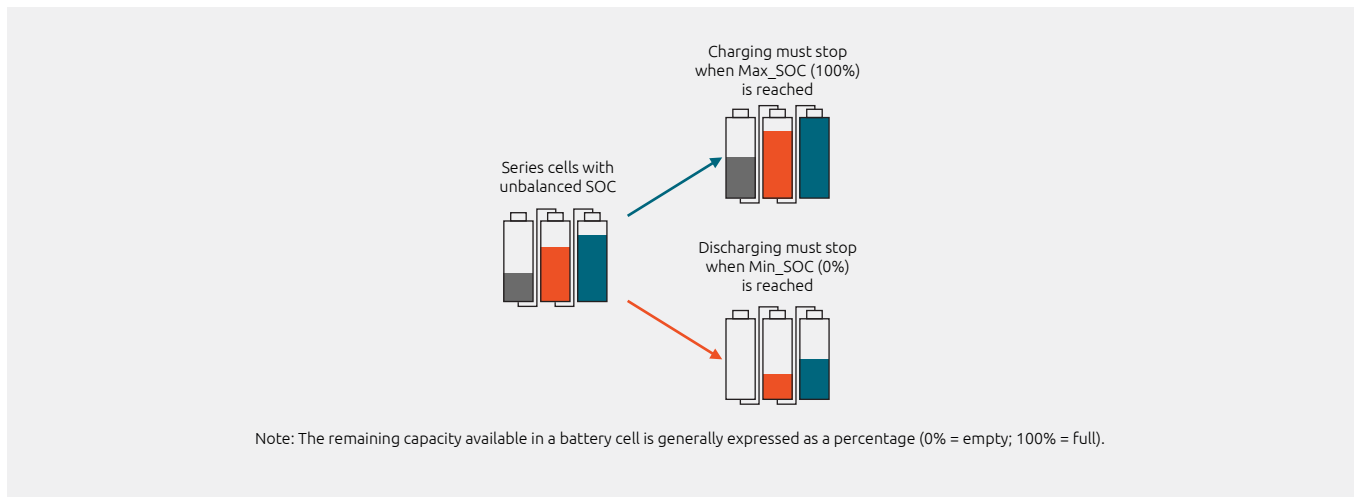


Fig 15. Cells can have different SoC either during charging or discharging

Accurate cell balancing is essential for maximizing battery pack life and ensuring safety, especially as automotive battery modules scale up in voltage and capacity. Traditional passive balancing dissipates excess charge as heat, leading to inefficiency and thermal management issues in high-capacity packs. Active balancing, which redistributes charge between cells using switched capacitors, inductors, or DC-DC converters, offers improved efficiency and overall battery life extension but introduces design complexity.

Key issues include:

- > High balancing currents: Transferring energy between cells at high rates requires robust switching components and thermal management.
- > Timing and control: Coordinating multiple balancing events without introducing noise or instability demands sophisticated algorithms and fast-response hardware.
- > Isolation and safety: In large packs, balancing circuits must be electrically isolated to prevent ground loops and ensure fault containment.
- > Component stress: Repeated switching and current surges can degrade MOSFETs, inductors, and capacitors, affecting long-term reliability.

These challenges are magnified in automotive-grade systems, where compliance with ISO 26262 and AEC-Q standards is mandatory.

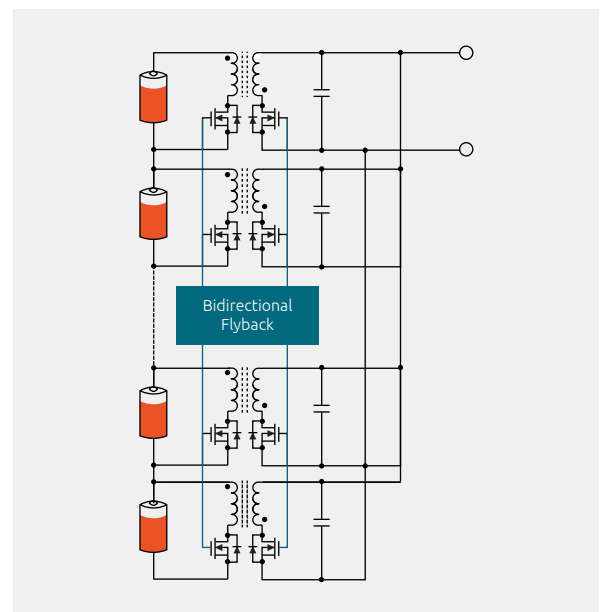


Fig 16. Active cell balancing using bidirectional flyback topology

## Nexperia Solutions

Nexperia's wide range of power MOSFETs, discrete diodes, and protection components enables the design of robust and efficient active balancing circuits tailored for high-current battery modules.

### Nexperia DFN2020-6 small signal MOSFETs driving efficient active cell balancing

Nexperia's DFN2020-6 MOSFETs deliver robust power handling in an ultra-compact 2 x 2 x 0.65 mm footprint, making them ideal for space-constrained battery management system (BMS) active cell balancing circuits. The DFN2020-6 package features copper wire bond technology to reduce package cost and the copper lead frame enhances thermal conductivity and electrical performance. This package serves as a modern, compact replacement for traditional SOT-223 and SOT-89 packages, offering significant PCB footprint reduction and improved heat dissipation.

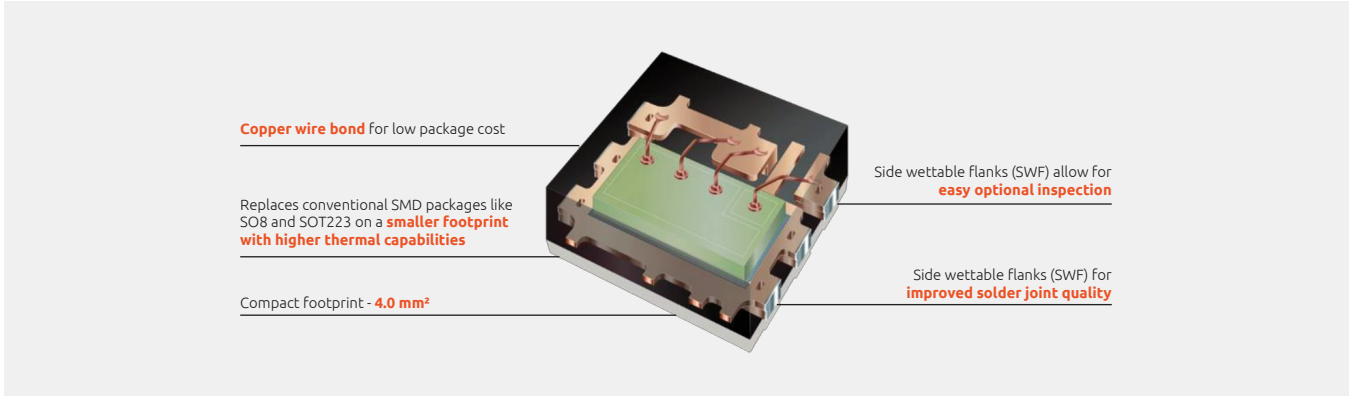


Fig 17. Properties of the DFN2020 package

Additionally, the DFN2020-6 MOSFETs incorporate side-wettable flanks, enabling automated optical inspection (AOI) and ensuring high manufacturing yield and process reliability. Available from 20 V upwards, these N-channel MOSFETs are well-suited for cell management in lithium-ion battery systems, where typical cell voltages range from approximately 4.2 V to 4.6 V, necessitating slightly oversized VDS ratings for safe operation.

With on-resistance  $R_{DS(ON)}$  as low as 16 mΩ at a 4.5 V gate drive, these MOSFETs minimize conduction losses during high-current active balancing operations, reducing heat generation and enhancing system reliability.

Experience the next level of BMS efficiency and miniaturization with Nexperia's DFN2020-6 MOSFET family. Visit Nexperia website for datasheets, design resources, and samples ordering.

Suggested Nexperia MOSFET: BUK4D1620						
$V_{DS}$	$V_{GS}$	$I_D$	$V_{GSth}$	$V_{GSth}$	$R_{DS(ON)}$	$Q_{G(tot)}$ [typ]
(V)	(V)	(A)	min (V)	max (V)	@ $V_{GS}=4.5$ V	
20	12	26	0.6	1.3	16	9.8




Fig. 18. Properties of BUK4D1620

## 4.2 Maintaining a safe operating envelope of the battery pack

Battery packs have strict operating boundaries for current, voltage, and temperature. Exceeding these limits during high rate charging or discharging can lead to overheating, accelerated aging, capacity loss, or even catastrophic failure. In EV charging, current levels can exceed hundreds of amps, the BMS must continuously monitor and enforce current limits to maintain safety and performance.

The safe operating envelope is defined by manufacturer specifications and dynamic conditions such as temperature voltage and SoC characteristics as shown the figures below.

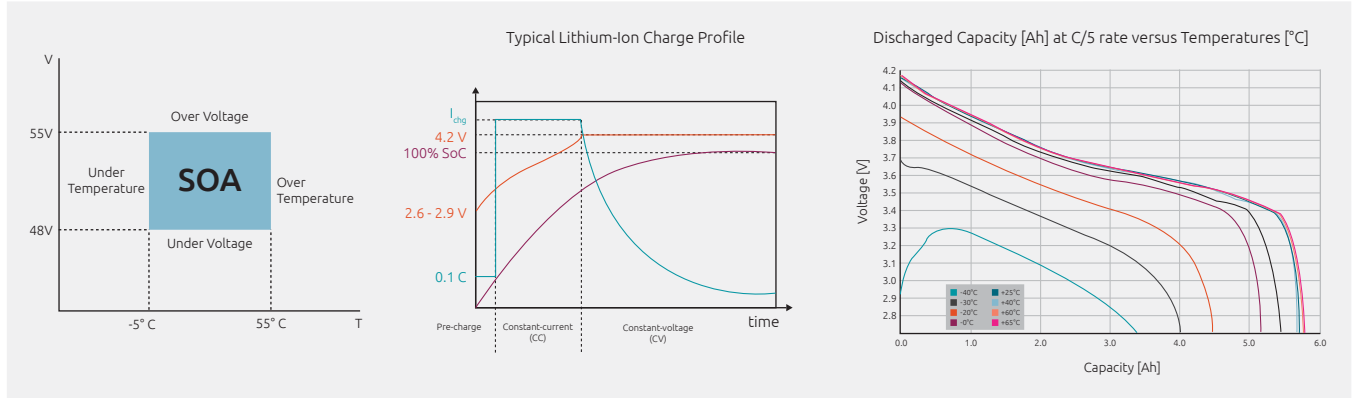


Fig 19. Typical operating conditions of battery cells provided by cell manufacturers

The BMS must detect when the boundaries approach unsafe thresholds and respond by throttling power, disconnecting loads, or alerting the vehicle control unit. This requires fast, accurate current sensing and reliable switching components capable of handling high currents without introducing excessive losses or latency.

### Nexperia Solutions

#### Shunt regulators

Nexperia offers three-terminal adjustable precision shunt regulators like the TL431 Family (e.g., TL431BFDT) with programmable output voltages up to 36 V using external resistors, suitable for BMS voltage reference and control needs. These elements can act as precision voltage references or as part of overvoltage protection and supervisory circuitry to detect and trigger protective responses rapidly if voltage limits are exceeded. Their three-terminal structure offers ease of integration into voltage monitoring loops or isolated feedback circuits within the battery management system.

#### Suggested Nexperia Shunt Regulator: TL431BFDT

- > Programmable output voltage up to 36 V
- > Three different reference voltage tolerances
- > Standard grade: 2 %
- > A-Grade: 1 %
- > B-Grade: 0.5 %
- > AEC-Q100 qualified

Fig 20. Properties of the TL431BFDT shunt regulator

TL431BFDT (SOT23 package) is a widely used adjustable shunt regulator with 0.5% reference voltage tolerance, programmable up to 36 V, making it a versatile choice for BMS voltage supervision and regulation circuits in EVs.

## Zener diodes

Zener diodes provide a stable reference voltage (e.g., 5.6 V, 12 V) regardless of supply fluctuations. This reference is used in comparator circuits to evaluate sensor outputs (e.g., temperature, voltage, current) as shown in the example circuit below.  $V_{IN}$  can be a temperature sensor output, and it is compared against Zener reference to trigger cooling or shutdown flag.

Nexperia Zener diodes offer a strong technical value proposition for voltage reference for comparator circuits. The 50  $\mu$ A Zener diode range is optimized for low bias current, reducing power consumption in always-on BMS monitoring circuits. Available in SOD323, DFN1006BD-2, and other space-saving SMD packages, enabling high-density PCB layouts. Covering a voltage range from 2.4 V up to 75 V with tolerance options of  $\pm 5\%$ ,  $\pm 2\%$ , and in some cases  $\pm 1\%$ , this extensive portfolio enables precise voltage clamping and stabilization tailored to diverse automotive electronics requirements.

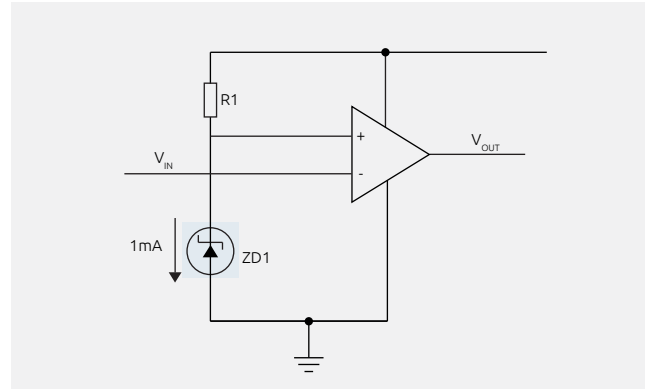


Fig 21. Zener diode as a reference for comparator circuits

## Suggested Nexperia Zener Diodes

### BZX series

- > Operating point specified at 50  $\mu$ A
- > Working voltage range: nominal 1.8 V to 75 V
- > Voltage tolerance about  $\pm 5\%$  ( $\pm 1\%$  available)



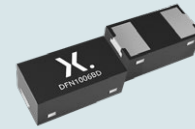
SOT23



SOD323F  
(SC-90)



SOD323  
(SC-76)



DFN1006BD-2  
(SOD882BD-2)

### PZU series

- > Low-differential resistance and low leakage Zener diodes
- > Overswing proof design
- > Working voltage range: nominal 2.4 V to 51 V
- > Voltage tolerance B=  $\pm 5\%$ , B2=  $\pm 2\%$

Fig 22. Suggested Nexperia Zener Diodes

## 4.3 Achieving reliable contactor control to connect and disconnect the battery pack to various loads

Contactors are critical electromechanical switches used to connect or disconnect the high voltage battery pack from the rest of the system for safety and operational control. A contactor's internal structure typically includes a coil-driven electromagnetic mechanism that actuates movable contacts, which physically open or close the high current path.

Operating a contactor involves energizing the coil by applying a voltage to generate a magnetic field, causing the contacts to close and connect the circuit. De-energization allows the contacts to open and disconnect the circuit. To achieve reliable and efficient operation, the control circuit must manage the coil current in three distinct stages as shown in the figure below.

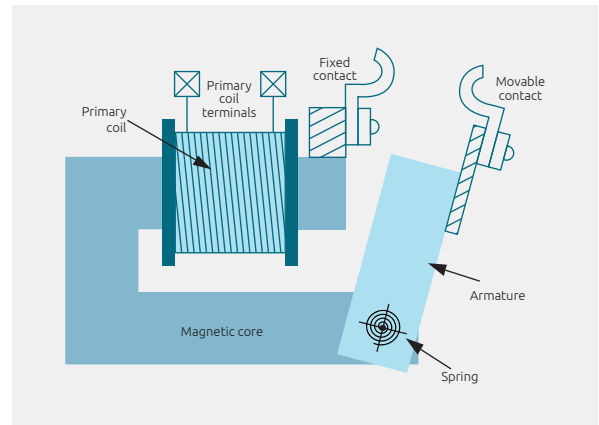


Fig 23. Contactor's mechanical layout

The circuit first provides a high current "pull-in" pulse (typically 2 - 5 A for 10 – 50 ms) to achieve rapid contact closure, then transitions to a reduced "hold" current, often up to 25% of the initial current value to sustain contact without excessive power loss or overheating. For rapid deactivation, a higher voltage flyback is implemented to quickly dissipate the coil's stored energy and speed up contact opening.

Pull-in and hold currents are dictated by coil and contactor design, coil voltages in automotive designs are commonly 12 V or 24 V, with inductances from 1 mH up to 100 mH. These parameters directly affect response time, energy consumption, and thermal performance.

The core technical challenge is to control contactors in a way that reliably connects and disconnects high-voltage battery packs under significant current and voltage stress, while minimizing energy loss, avoiding coil overheating, and ensuring that switching is quick and safe under all operational conditions. This demands robust circuitry and effective drive management tailored to automotive battery management systems.

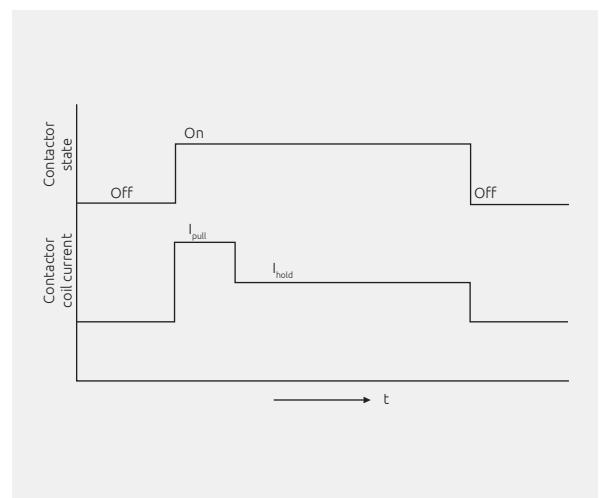


Fig 24. Current profile of contactor operation typically has multiple stages

## Nexperia Solutions

The proposed technical solution using Nexperia products employs automotive-grade MOSFETs to provide efficient and robust electronic control of contactor coils. Nexperia offers a range of MOSFETs that are well-suited for these applications due to their low  $R_{DS(on)}$ , high current capability, robust avalanche energy handling, and thermal performance.

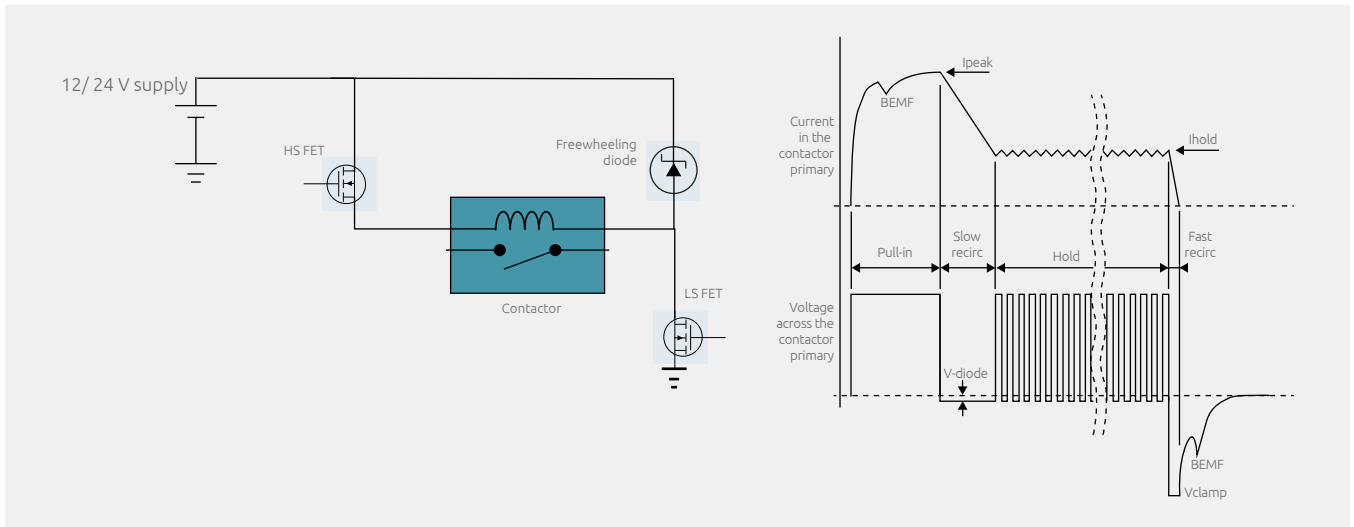


Fig 25. Nexperia's solution for contactor control using two MOSFETs and a Schottky diode

As shown in figure 25, this circuit can be operated in both pull in and hold stages, as well as turn-off and freewheeling stages. This is how it works:

- The high-side HS MOSFET controls the power supply to the contactor coil and conducts during both the pull-in and hold phases. The low-side LS MOSFET also conducts continuously during pull-in mode to complete the circuit path. Once the coil current reaches its peak and the contactor closes, the LS MOSFET is turned off, and the coil current freewheels through the diode, while the HS MOSFET remains on. This freewheeling period occurs between the pull-in and hold phases, allowing the coil current to decay gradually to the hold current level. The duration of this recirculation time depends on coil inductance and coil resistance. If the recirculation time is too long, the current may drop below the minimum hold current, causing the contactor to open.
- Alternatively, the LS MOSFET can be modulated with PWM at a low duty cycle, allowing controlled current decay until the hold current is reached. During the hold phase, the LS MOSFET performs PWM to regulate and maintain the coil current at the desired level. The PWM frequency and duty cycle settings can be calculated based on coil inductance, resistance, and supply voltage, while accounting for variations in coil resistance due to temperature changes.
- For turn-off, the LS MOSFET PWM is disabled, and the HS MOSFET remains on for a short interval to ensure safe and gradual dissipation of the coil's stored energy.

Nexperia offers a wide range of MOSFETs solutions for the LS and HS operation, in addition, Schottky diodes are available too. Key criteria for MOSFET selection include voltage and current ratings, on-resistance  $R_{DS(on)}$ , switching speed, and package thermal performance. Both MOSFETs must have voltage ratings at least 20% higher than the coil supply voltage (e.g., 40 V for 12 V or 60 V for 24 V coils) to provide margin against inductive voltage spikes. Low  $R_{DS(on)}$  values are critical to minimize conduction losses during the high current pull-in and hold phases, thereby improving efficiency and reducing heat dissipation. Fast switching capability and low gate charge ensure responsive PWM control and reduced switching losses.

## 40 V low $R_{DS(ON)}$ Automotive MOSFETs

Nexperia's automotive MOSFETs, such as those in the LFPAK33/56/88 families, provide current handling capability. These MOSFETs offer extremely low  $R_{DS(ON)}$  and high avalanche energy ratings allowing them to handle high currents with minimal power loss and heat generation. Their high current handling and automotive-grade reliability make them ideal for active balancing circuits.

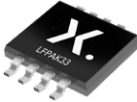


LFPAK56 5 mm x 6 mm BUK7Y1R4-40H		190 A
LFPAK56D family 5 mm x 6 mm BUK7V4R4-40H		98 A
LFPAK33 3 mm x 3 mm BUK7M3R3-40H		80 A

Fig 26. Nexperia has a wide range of 40V rated LFPAK MOSFETs

The 40 V MOSFETs family is available in a variety of packages as shown in the figure above, these feature the super-junction Trench 9 (T9) technology from Nexperia and offers an improved avalanche ruggedness and Safe Operating Areas (SOA) compared to competitor parts. The T9 super junction enables high current capability and helps keeping the heating effect under control to deliver best-in-class SOA rating compared to competition.

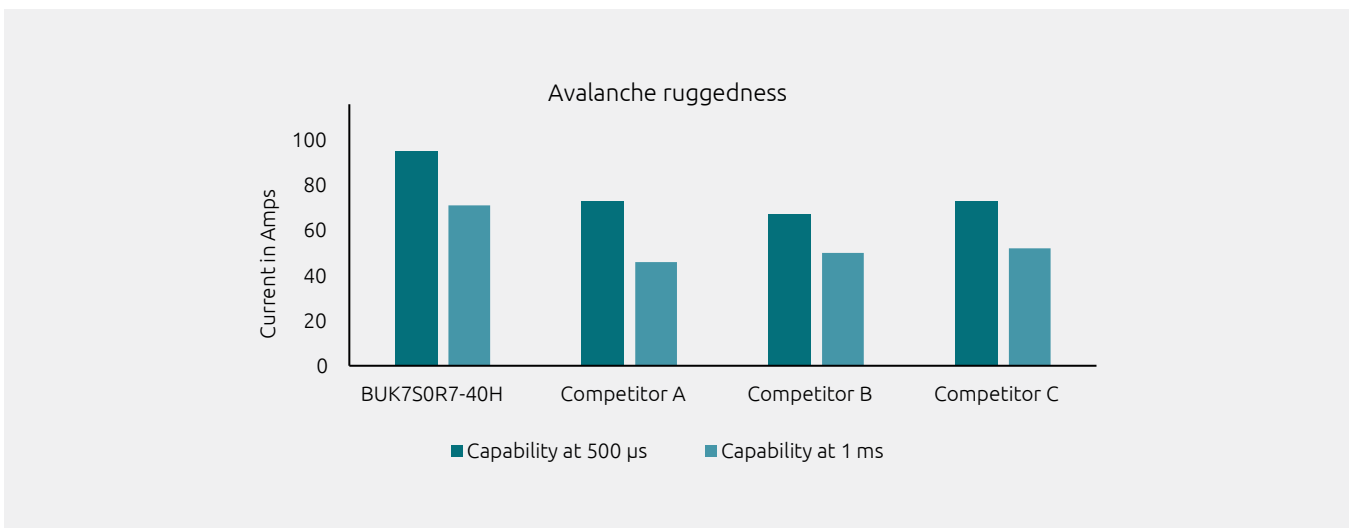



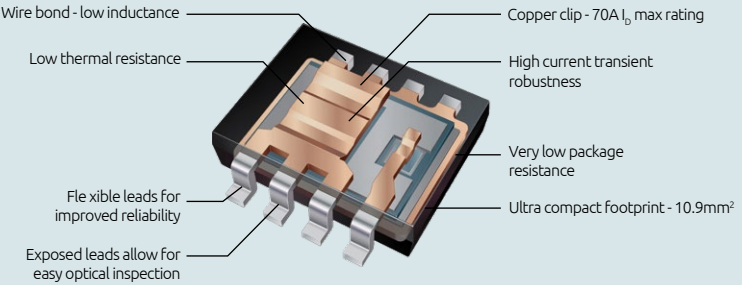
Fig 27. The 40V MOSFETs use T9 technology providing robust SOA and Avalanche ruggedness

LFPAK33 are a strong choice for both HS and LS MOSFETs due to their compact 3.3 mm x 3.3 mm footprint, which enables significant PCB space savings compared to traditional packages. These devices feature low on-resistance  $R_{DS(ON)}$  values typically in the single milliohm range for 40 V parts resulting in lower conduction losses during the pull-in and hold phases. The LFPAK33 package also offers excellent thermal performance thanks to its low package resistance and copper clip technology, allowing continuous currents up to around 30–70 A depending on the specific device and cooling conditions, which comfortably covers typical 2–5 A coil currents with a robust margin.

**40 V LFPAK33 packaged devices for HS and LS MOSFETs with 3.3 – 20 mΩ  $R_{DS(ON)}$  [max] @  $V_{GS} = 10 V$**

LFPAK pins absorb stresses associated with thermal expansions and mechanical strains from PCB bending & flexing





- Wire bond - low inductance
- Low thermal resistance
- Flexible leads for improved reliability
- Exposed leads allow for easy optical inspection
- Copper clip - 70A  $I_b$  max rating
- High current transient robustness
- Very low package resistance
- Ultra compact footprint - 10.9mm<sup>2</sup>

Fig 28. Properties of 40 V LFPAK33 MOSFETs

## Trench low $V_f$ Schottky barrier diodes for freewheeling

Similarly for the freewheeling diode, a margin on 20% for the voltage rating is adequate to recirculating coil current during the freewheeling time. Nexperia has wide variety of Schottky diodes for with very low forward voltage drop and fast recovery capabilities for efficiency. The [PMEG40T50EP-Q](#) is an excellent trench Schottky diode choice for contactor coil freewheeling applications BMS applications. It has the following key specifications.

### Suggested Nexperia's Schottky Diodes: PMEG40T50EP-Q



- › Average Forward Current ( $I_F$ ): 5 A, which matches well with typical coil currents of 2–5 A, ensuring reliable continuous operation.
- › Reverse Voltage ( $V_R$ ): 40 V, providing sufficient margin for inductive voltage spikes from 12 V and 24 V coils.
- › Low Forward Voltage Drop ( $V_F$ ): This contributes to reduced conduction and switching losses, improving overall efficiency and thermal performance.
- › Low Leakage Current due to advanced trench MEGA Schottky technology, enhancing reliability.
- › Package: Surface mount SOD-128 (industry-standard for thermal and mechanical robustness).
- › AEC-Q101 qualified

Fig 29. Low forward voltage 40V Schottky diodes

Nexperia regularly publishes application notes to support designers on the performance of MOSFETs for driving inductive loads, [AN50020](#) and [AN50003](#) Application notes presents capabilities, performance, test results and validation of reliability of Nexperia MOSFETs for inductive loads.

## 4.4 Approach for powering auxiliary circuits

While the main battery operates at 400–800 VDC, the BMS control board and its auxiliary circuits such as microcontrollers, CAN/LIN transceivers, EEPROMs, and temperature sensors require tightly regulated low-voltage rails like 5 V, 3.3 V, and 1.8 V.

These auxiliary circuits are often powered from a 12 V or 24 V auxiliary battery, which introduces a new design challenge: how to efficiently and reliably convert 12–24 V input to multiple low-voltage outputs in a compact, thermally constrained, and safety-critical environment.

Typical auxiliary power requirements are:

- › Input voltage range: 9–32 V (to account for cold crank and load dump)
- › Output voltages: 5 V, 3.3 V, 1.8 V
- › Output current: 0.5–2 A per rail
- › Total power: 5–15 W

The challenge lies in efficiently and safely stepping down 12 V or 24 V rails to low-voltage domains while meeting stringent automotive requirements for:

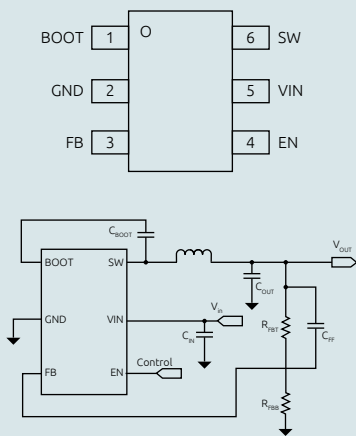
- › Isolation
- › EMI performance
- › Thermal efficiency
- › Compact size

### Nexperia Solutions

#### 4.5 V to 40 V, 0.6 A synchronous buck converter

The NEX40400-Q100 is a compact, automotive-qualified synchronous step-down converter ideal for this application. These buck converters deliver high efficiency and low noise, supporting a wide input voltage range suitable for automotive battery stacks. The NEX40400-Q100 achieves >90% efficiency at typical loads, reducing heat dissipation in compact enclosures. Their compact design and integrated protection features simplify power supply design for BMS auxiliary loads.

#### Suggested Nexperia's Buck converter: NEX40400-Q100



- › Wide Input Range: 4.5 V to 40 V, supports 12 V and 24 V systems
- › Output Current: Up to 600 mA continuous output current
- › Switching Frequency: 1.0 MHz or 2.1 MHz options allow small inductors and capacitors
- › Efficiency: High efficiency even at low dropout, with PFM mode for light load operation
- › EMI Performance: Spread spectrum and forced PWM mode reduce conducted and radiated noise
- › Protection Features: Internal soft start, hiccup mode for overload, precision enable pin
- › Package: TSOT23-6 - 2 x 3 mm for minimal footprint
- › AEC-Q100 qualified

Fig 30. Nexperia's NEX40400-Q100 synchronous buck converter IC

The graph on the right shows NEX40400-Q100 operating at 1.05 MHz FPWM across three input voltages (15 V, 24 V, 36 V). At low-to-mid load currents (10 mA to ~200 mA), NEX40400 achieves up to 10% higher efficiency compared to the competitor products. Efficiency remains consistently high across 15 V, 24 V, and 36 V inputs with output currents above 100 mA, ensuring robust performance under varying automotive conditions. Higher efficiency at full loads reduces power dissipation, minimizing heat generation in compact BMS enclosures. This translates to simpler thermal management and improved reliability.

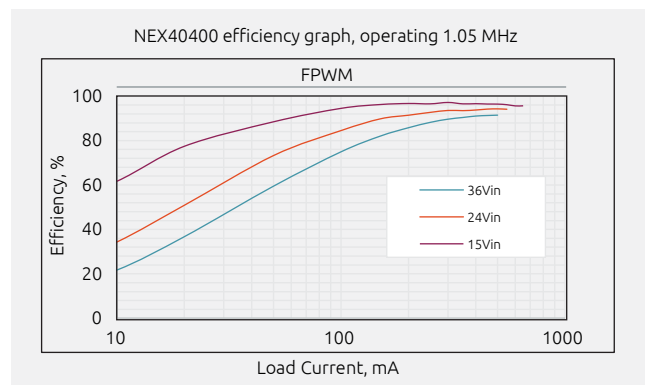


Fig 31. Efficiency graphs of the NEX40400 at 1.05 MHz switching frequency

For further information, Nexperia provides [NEX40400EVM-05](#) Evaluation boards which can be used to test the [NEX40400-Q100](#) under varying conditions. A small form factor inductor rated 18  $\mu\text{H}$ , 1.5 A is included, and these can be changed to suit any application or test need.

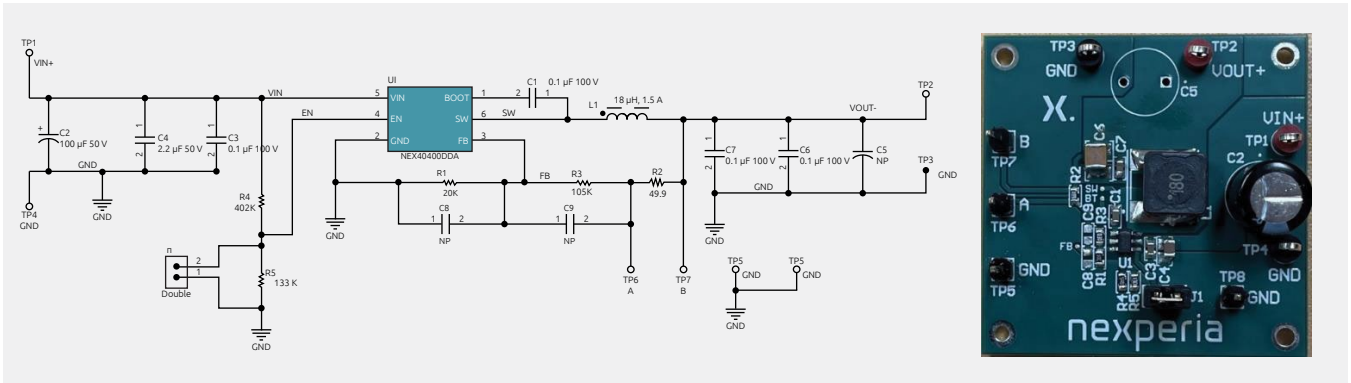


Fig 32. Board schematic and PCB top view of the NEX40400 evaluation board

## 4.5 What strategies protect sensitive BMS circuitry from voltage transients and surges?

BMS operate in harsh environments where voltage transients and surges are common. These disturbances can originate from:

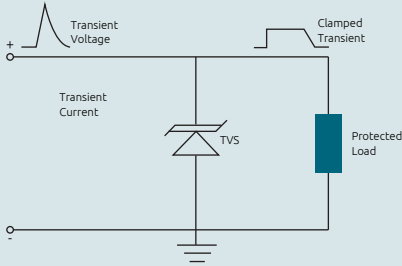
- > Load dump events (alternator disconnect): up to +100 V for hundreds of milliseconds.
- > Inductive switching transients: spikes of  $\pm 60$  V for microseconds.
- > Electrostatic discharge (ESD): up to  $\pm 15$  kV air discharge.

Sensitive BMS components (microcontrollers, sensing ICs, communication interfaces) typically operate at 5 V or 3.3 V, making them highly vulnerable to these conditions. Failure modes may cause permanent damages to ICs, data corruption or reduced lifetime due to overstress. Solution needs to address these conditions that can cause the transients in the sensitive parts of the designs and Nexperia has the right solution for these design considerations.

### Nexperia Solutions

TVS (Transient Voltage Suppression) diodes from and Electrostatic Discharge (ESD) diodes from Nexperia are specifically designed for automotive applications, providing fast-acting clamping of voltage spikes and robust ESD protection. These devices are placed at critical nodes to safeguard communication lines, sensor inputs, and power rails, ensuring system reliability and compliance with automotive EMC standards. PTVS10VS1UR can be placed close to CAN/LIN transceivers or MCU pins to protect power lines feeding BMS ICs from load dump surges.

**Recommended Part: PTVS10VS1UR**  
**For power lines (12 V systems)**

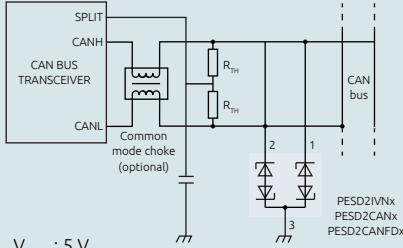


- >  $V_{RWM}$ : 10 V
- >  $V_{BR}$ : 11.1 V
- >  $V_{CL}$  @ 100 A surge : ~17 V
- >  $P_{PPM}$ : 400 W (10/1000  $\mu$ s)

PTVS10VS1UR clamps surge to ~17 V, preventing damage to downstream electronics rated for 12–18 V.

Fig. 33. BMS solution for protection against voltage transients

**Recommended Part: PESD5V0S1UL**  
**For signal lines (CAN, LIN & MCU I/O)**



- >  $V_{RWM}$ : 5 V,
- >  $V_{BR}$ : 6 V
- >  $V_{CL}$  @ 8 A surge : ~9 V
- >  $P_{PPM}$ : 150 W (8/20  $\mu$ s)
- > ESD :  $\pm 15$  kV (IEC 61000-4-2)

PESD5V0S1UL ensures CAN/LIN transceivers see <9 V during fast spikes, avoiding latch-up or failure

Fig 34. BMS solution for protection against ESD

## 4.6 Reliable logic level shifting between BMS integrated circuits operating at different voltage domains

Semiconductor evolution has led to the coexistence of many different digital voltage domains. Early systems relied on 5.0 V bipolar TTL (Transistor-Transistor Logic) families, but the transition to 5.0 V CMOS (Complementary Metal-Oxide Semiconductor) significantly reduced system power consumption, creating the first need for TTL to CMOS voltage translation. As digital subsystems became faster and more compact, 3.3 V CMOS logic emerged, enabling improved memory access times and higher clock speeds. The continuous push toward lower power further introduced 1.8 V, 1.5 V, 1.2 V and even 0.8 V logic voltage classes.

The result is that electronics rarely operate at a single digital voltage. Instead, they incorporate multiple supply rails optimized for performance, efficiency, or legacy compatibility. This diversity makes voltage translation a fundamental requirement to guarantee reliable interoperability across subsystems

This challenge is even more pronounced in automotive BMS. A BMS typically integrates a wide range of devices such as cell monitoring ICs, balancing controllers, microcontrollers, temperature sensors, isolation interfaces, memories, and communication transceivers, each potentially operating at different logic voltages. For example:

- › Cell monitoring ICs and sensor frontends may operate at 1.8 V or 2.5 V
- › Module controllers or pack controllers often run at 3.3 V or 5.0 V
- › Communication interfaces (SPI, I<sup>2</sup>C, GPIO status lines) may exist at various voltage islands
- › Wake/sleep pins and safety indicators may require interfacing between low-voltage logic and 5 V rated microcontrollers

As battery packs scale in complexity and modularity, designers frequently encounter situations where devices must communicate across incompatible voltage domains, sometimes across long traces within the pack or through harnesses between modules. Without proper translation, system risks include:

- › Unreliable logic detection
- › Back-powering of low-voltage devices
- › Increased leakage or shoot-through currents
- › Reduced EMC robustness in the electrically noisy environment of a high-voltage battery

Thus, the need for dedicated voltage-level translation is not only historical, but also now a critical requirement for robust and safe automotive BMS communication.

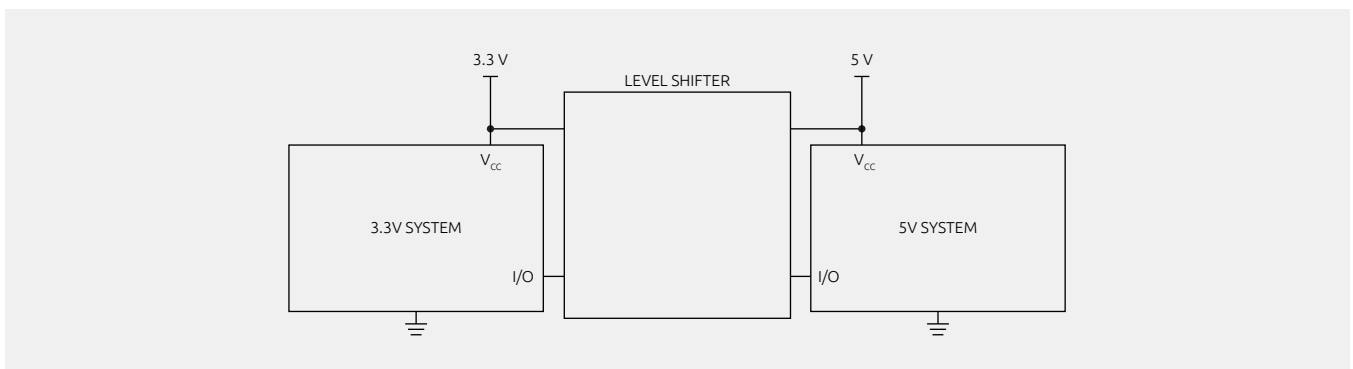


Fig 35. Level shifting is used for translating signals between different voltage domains

## Nexperia Solutions

To address the challenges created by mixed voltage digital interfaces in Battery Management Systems (BMS), Nexperia offers a broad portfolio of automotive-qualified logic-level translators engineered for robustness, low power consumption, and signal integrity.

Electronic devices have input levels ( $V_{IH}$  and  $V_{IL}$ ) and output levels ( $V_{OH}$  and  $V_{OL}$ ).  $V_{IH}$  is the high-level input voltage, if a voltage is applied that is  $> V_{IH}$ , it will be seen as a logic HIGH.  $V_{IL}$  is the low-level input voltage, if a voltage is applied that is  $< V_{IL}$ , it will be seen as a logic LOW.  $V_{OH}$  is the high-level output voltage at a specified output current.  $V_{OL}$  is the low-level output voltage at a specified output current.

### Unidirectional High to low level translation with the LVC family ICs

For unidirectional high-to-low level translation, Nexperia's LVC family provides an excellent set of devices thanks to their 5.5 V tolerant inputs, low propagation delay, and wide operating voltage range. When an MCU operating at 3.3 V or 5.0 V must safely drive a lower-voltage device such as a 1.8 V or 2.5 V CMIC (Cell Monitoring integrated Circuit), an LVC buffer can be powered at the lower domain while accepting the higher-voltage input directly, ensuring clean CMOS-level outputs without risking over-voltage stress. Nexperia's LVC families allow the input pin to accept voltages higher than their VCC and shift the signal to a lower voltage domain as demonstrated in Figure 36 below.

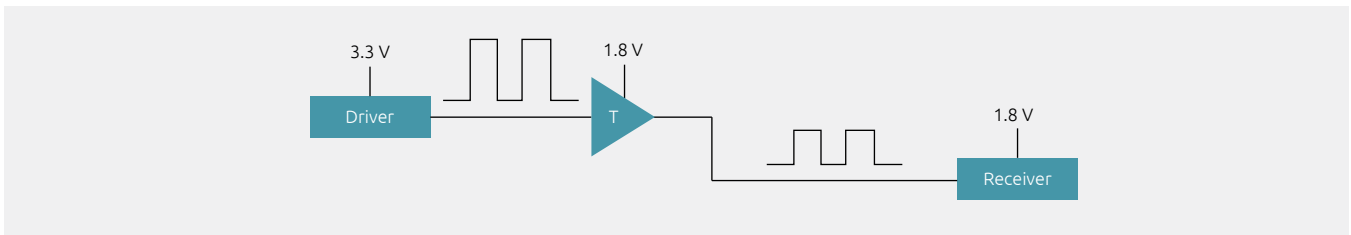


Fig. 36 Unidirectional high to low level voltage translation

The LVC families have 5 V input tolerances with no external resistors required to pull the voltage up. This is ideal for SPI, PWM and multi-signal GPIO ports to form connection from the high voltage side to a lower domain. A recommended device for this application is the 74LVC1G14, a Schmitt-trigger buffer with 5 V tolerant inputs when powered from 1.65 - 3.6 V, making it ideal for translating 3.3/5 V to 1.8/2.5 V logic while adding noise immunity for long BMS traces.

### Recommended Part: 74LVC1G14-Q100

Multiple package options



- > Wide supply voltage ranges from 1.65 V to 5.5 V
- > Schmitt-triggered inputs
- > High noise immunity
- > CMOS low power dissipation
- > Direct interface with TTL levels
- > Multiple package options
- > ESD protection: HBM: ANSI/ESDA/JEDEC JS-001 class 3A exceeds 5000 V

Fig. 37 74LVCxxx ICs family for unidirectional translation from high level to low level voltages

### Unidirectional low to high level translation with the AUP family ICs

Unidirectional low-to-high level translation is required when a low-voltage device (typically 1.2 V, 1.8 V, or 2.5 V) must reliably drive a higher-voltage logic input such as 3.3 V or 5.0 V, ensuring that the lower-voltage logic "1" is interpreted correctly without violating device thresholds or causing timing degradation. In BMS architecture, this occurs frequently, for example, when 1.8 V CMIC status lines or SPI outputs must interface with a 3.3 V or 5.0 V microcontroller.

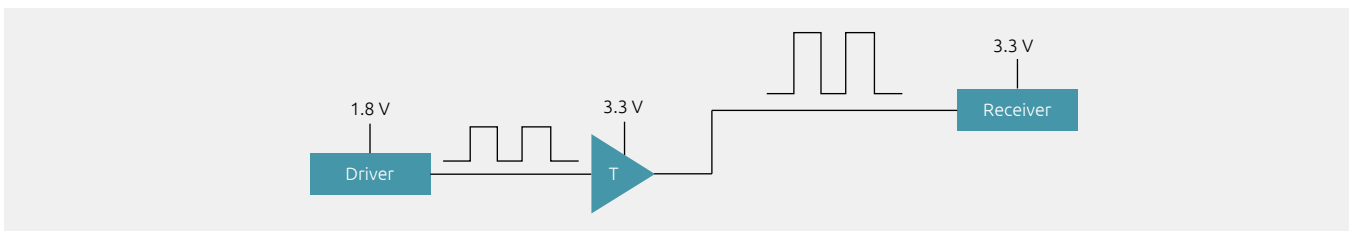


Fig. 38 Unidirectional low to high voltage translation

A robust solution must provide CMOS-compatible thresholds, low propagation delay, and fail-safe behavior across the automotive temperature range. Nexperia's 74AUP1T34 is an excellent choice for this application. It offers true low-voltage input acceptability, clean rail-to-rail 3.3 V or 5.0 V output, ultra-low static power, fast edge rates, and fail-safe I/Os, making it ideal for translating low-voltage BMS signals to higher-voltage controller domains with high noise immunity and minimal load impact.

### Recommended Parts: 74AUP1T34 -Q100

Multiple package options



- > Wide supply voltage ranges from 1.1 V to 3.6 V
- > Schmitt-trigger action at all inputs
- > High noise immunity
- > Low static power consumption
- > Overvoltage tolerant inputs to 3.6 V
- > ESD protection:
  - HBM: ANSI/ESDA/JEDEC JS-001 class 3A exceeds 5000 V
- > Multiple package options

Fig. 39 74AUPxxx ICs family for translation from low to high voltage

### Bi-directional translators with Auto direction Sense with the NXS family ICs

Bidirectional level translation with auto-direction sensing is essential when two devices operating at different voltage domains must both be able to drive the same bus without predefined direction control. Common in protocols like I<sup>2</sup>C, SMBus, or shared ALERT and diagnostic lines in BMS modules require bi-directional level translation. These interfaces rely on open-drain signaling, where direction can change dynamically on every bit, requiring the translator to sense which side is actively pulling the line low and propagate that state to the opposite side without adding noticeable delay, distortion, or violating the pull-up requirements of either domain.

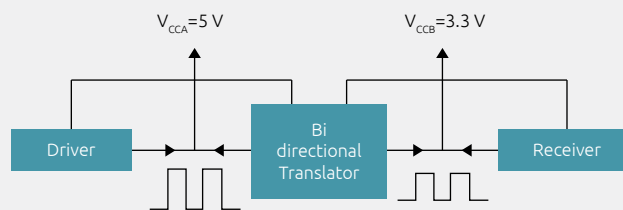
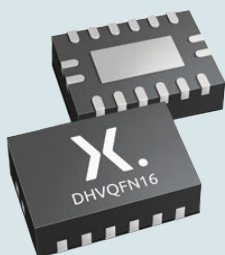


Fig. 40 Bi-directional translators with Auto direction Sense

A strong bidirectional autosense level-translation solution from Nexperia's NXS families is the NXS0104-Q100 (open-drain optimized). The NXS family is designed for open-drain topologies (ideal for I<sup>2</sup>C/SMBus) and integrates a pass-switch architecture with edge-rate acceleration and internal pull-ups, operating across  $V_{CCA} = 1.65 - 3.6$  V and  $V_{CCB} = 2.3 - 5.5$  V, making it suitable for I<sup>2</sup>C-level shifting between 1.8 V CMICs and 5 V MCUs.

### Recommended Parts: NXS0104-Q100

Multiple package options



- > Wide supply voltage range:
  - >  $V_{CCA}$ : 1.65 V to 3.6 V and  $V_{CCB}$ : 2.3 V to 5.5 V
- > Auto direction sensing
- > High noise immunity
- > Inputs accept voltages up to 5.5 V
- > Maximum data rates: Push-pull: 24 Mbps
- > ESD protection: HBM: ANSI/ESDA/JEDEC JS-001 class 2 exceeds 2500 V for A port
- > Multiple package options

Fig. 41 NXSxxxx ICs family for bidirectional translation with autosense capabilities

# 5. Recommended products

Technology	Description	Key part numbers
<b>Power Management</b>		
<b>MOSFETs</b>	20 - 40 V N-ch MOS, for active or passive cell balancing, from 13 A ID continuous, extra low VGS, th, DFN2020	<a href="#">BUK4D16-20</a> <a href="#">PMPB20XNEA</a>
<b>Zener Diodes</b>	Cell over-voltage protection in SOT23 and DFN, SOD packages, ±5% or ±1% tolerance	<a href="#">PZU84-xx-Q</a>
<b>Transformer Drivers</b>	Low-noise, 1.2 A push-pull transformer driver for push pull active balancing topologies SOT8061-1.	<a href="#">NXF6501-Q100</a> , <a href="#">NXF6505-Q100</a>
<b>Cell Monitoring</b>		
<b>Zener Diodes</b>	Providing reference voltages for operational amplifiers. Available in SOT23 and DFN packages. Various voltages from 3.6 V to 51 V.	<a href="#">BZX84-C4V7</a> , <a href="#">BZY84-C7V5</a> , <a href="#">BZX88505-Q</a>
<b>Digital Multiplexers</b>	Selects one out of N sensor data. 8 inputs to 1 output channel available.	<a href="#">NMUX1308PW-Q100</a>
<b>Control Board – Power Supply and Management</b>		
<b>Buck Converters</b>	4.5 V to 40 V, 600 mA, synchronous step-down converter, SOT8061-1.	<a href="#">NEX40400ADA</a> , <a href="#">NEX40400BDA</a> , <a href="#">NEX40400CDA</a> , <a href="#">NEX40400DDA</a>
<b>LDOs</b>	150/300 mA, 40 V ultra-low Iq (5.3 µA) low-dropout voltage regulator in HTSSOP8.	<a href="#">NEX90X30-Q100</a>
<b>Load switches</b>	5.5 V, 15-55 mΩ, current limit from 110 mA to 6 A, SOT8044-1 or SOT457.	<a href="#">NPS4053-Q100</a> , <a href="#">NPS3005GP-Q100</a>
<b>Voltage Translators</b>	1/2/4-bit dual supply translating transceiver; open drain; auto direction sensing	<a href="#">NXS</a> , <a href="#">NXB series</a> , <a href="#">AUP</a> , <a href="#">LVC families</a>
<b>Schottky Diodes</b>	30 V planar Schottky barrier diodes, SOT23	<a href="#">BAT754 series</a> , <a href="#">1PS70SB10-Q</a> , <a href="#">BAS40-04-Q</a>
<b>Zener Diodes</b>	> 2700 product types, 1.8 V to 75 V Zener Voltage, ±1% or ±5% tolerance, high power and low leakages options, SOD, DFN and SOT package varieties.	<a href="#">BZX84J</a> , <a href="#">BZT52 series</a> , <a href="#">PDZ-B-Q series</a> , <a href="#">PZUxB_B2-Q</a>
<b>Schottky Diodes</b>	30 V planar Schottky barrier diodes, SOT23	<a href="#">BAT754 series</a> , <a href="#">1PS70SB10-Q</a> , <a href="#">BAS40-04-Q</a>
<b>Bipolar Junction Transistors (BJTs)</b>	45 V, 500 mA NPN general-purpose transistors in SOT23 package	<a href="#">BC817-25QA</a> ; <a href="#">BC817-40QA</a> PNP complement: <a href="#">BC817QBH-Q series</a>
<b>Small Signal MOSFETs</b>	30-100 V, N-channel MOSFETs, low RDS(on), DFN, SC, WLCS and SOT packages	<a href="#">2N7002</a> , <a href="#">BUK4D110-20P</a> , <a href="#">BUK6D120-40E</a>
<b>TVS Diodes</b>	400/600 W Transient Voltage Suppressor, Reverse standoff voltage range: 3.3-64 V, SOD128 or SOD123W.	<a href="#">PTVSxP1UP</a> , <a href="#">PTVSxS1UR</a>
<b>Control Board - Communication Interfaces</b>		
<b>ESD Diodes</b>	LIN/CAN/FlexRay ESD diodes, uni or bi-directional, DFN or SOD packages.	<a href="#">PESD1CANFD24LS-Q</a> , <a href="#">PESD2CAN24LT-Q</a> , <a href="#">PESD1IVN24LS-Q</a>
<b>Digital Isolators</b>	4, 5 kV galvanic isolation, 250 kV/µs CMTI.	<a href="#">NXI77xx-Q100</a>
<b>Control Board - Signal processing</b>		
<b>Standard Logic ICs</b>	Logic gates, buffers, inverters, flip flops, latches in singular or multibyte circuits.	<a href="#">74AHC00-Q100</a> ; <a href="#">74AHCT00-Q100</a> , <a href="#">74AHCT240-Q100</a> , <a href="#">74ALVC32-Q100</a> , <a href="#">74AVC4T245-Q100</a>
<b>Multiplexers</b>	1.8 V general purpose SP8T-Z and 2x SP4T-Z analog switches with injection current control, micro packs, XSON, TSSOP16, SOT varieties,	<a href="#">NMUX1308-Q100</a> , <a href="#">NMUX1309-Q100</a>
<b>Resistor Equipped Transistors</b>	50-80 V, NPN or PNP RETs, various resistors combinations (single or dual), SOT23/SOT323/DFN1412D-3/DFN1110D-3/DFN1006B-3	<a href="#">PDTA143/114/124/144EOA series</a> , <a href="#">PDTB1xxxT series</a> , <a href="#">PDTC124T series</a> , <a href="#">PEMD12</a> ; <a href="#">PUMD12</a>
<b>Control Board - Gate Driver Circuits</b>		
<b>Gate Drivers</b>	4 A, 120 V non isolated Half bridge or low side gate drivers, SOT packages	<a href="#">NGD4300-Q100</a> <a href="#">NGD31251D</a>
<b>Bipolar Junction Transistors (BJTs)</b>	45 V, 500 mA NPN general-purpose transistors in SOT23 package	<a href="#">BC817-25QA</a> ; <a href="#">BC817-40QA</a> PNP complement: <a href="#">BC817QBH-Q series</a>
<b>Switching diodes</b>	Low leakage switching diodes, SOD and DFN low-profile packages.	<a href="#">BAS116-Q</a> , <a href="#">BAV170-Q</a> , <a href="#">BAV199-Q</a> , <a href="#">BAW156-Q</a>

# 6. References

## Nexperia handbooks

[MOSFET and GaN FET application handbook](#)

[ESD Application Handbook](#)

[Bipolar Junction Transistor \(BJT\) Application Handbook](#)

[Diode fundamentals, characteristics and applications](#)

[Logic product features and application insights](#)

## Application notes

[AN50020 MOSFETs in Power Switch applications](#)

[AN50003 Driving solenoids in automotive applications](#)

[AN50001 Reverse battery protection in automotive applications](#)

[AN90016 Maximum continuous currents in NEXPERIA LFPACK power MOSFETs](#)

[AN90039 ESD protection devices for automotive Ethernet applications](#)

## Evaluation boards

[NEX40400EVM-05: 4.5 V to 40 V, 600 mA, FPWM, 1.05 MHz, synchronous step-down converter evaluation board](#)

[NEX40400EVM-12: 4.5 V to 40 V, 600 mA, PFM, 2.1 MHz, synchronous step-down converter evaluation board](#)

[NEX92730DPCD-Q100 300 mA, dual-channel antenna LDO with current sensing evaluation board](#)

[NEVB-NXF6505ADA evaluation board](#)

[NEVB-NMUX1309 Analog Switch Evaluation Board](#)

---

### © 2026 Nexperia B.V.

All rights reserved. Reproduction in whole or in part is prohibited without the prior written consent of the copyright owner. The information presented in this document does not form part of any quotation or contract, is believed to be accurate and reliable and may be changed without notice. No liability will be accepted by the publisher for any consequence of its use. Publication thereof does not convey nor imply any license under patent- or other industrial or intellectual property rights.

[nexperia.com](https://www.nexperia.com)

### Date of release:

February 2026

