



Automotive

Communication Interface

nexperia.com

nexperia

Contents

1. Introduction	3
<hr/>	
2. Design challenges and solutions	4
2.1 Protecting data lines from external voltage surges and bursts	4
2.2 Adapting signals to the processor input specifications	7
2.3 Using digital isolation for additional safety measure	8
<hr/>	
3. Recommended products	10
<hr/>	
4. References	11
<hr/>	



1. Introduction

Every automotive application can be divided into functional blocks in terms of the electronics that they contain. First of all, there are electronic blocks that deal with power and electronic blocks that deal with information. Both of them have an interface to the surrounding environment and a main hub for processing the information or power.

In this respect the power electronics blocks are:

- > Power Input Protection
- > Power Management

While the signal electronics blocks are

- > Communication Interface
- > Signal Processing

These four blocks define a basic automotive Electronic Control Unit (ECU). However, there is no use of having an Automotive ECU without its main functionality. A fifth block is therefore necessary in order to provide the means for controlling the main functionality of the application:

- > Load Management

Therefore, the Load Management block is specific for every application: LED drivers for lighting units; MOSFET inverters for BLDC drivers; radar transmitters; camera lenses; lasers for lidars; amplifiers for audio and antennas for wireless communications.

The first four blocks are universal for most applications in their nature. However, there might be a difference in their scales. A central computer or ADAS control unit might have a large Signal Processing requirement that would require fast Communication Interface and substantial power requirements for the Power Management and Input Protection blocks. Compared to a lighting module that would still require substantial power but much less signal processing and communication bandwidth.

The interconnections of these blocks within the application of a Zone Control Unit are displayed below in Fig. 1.

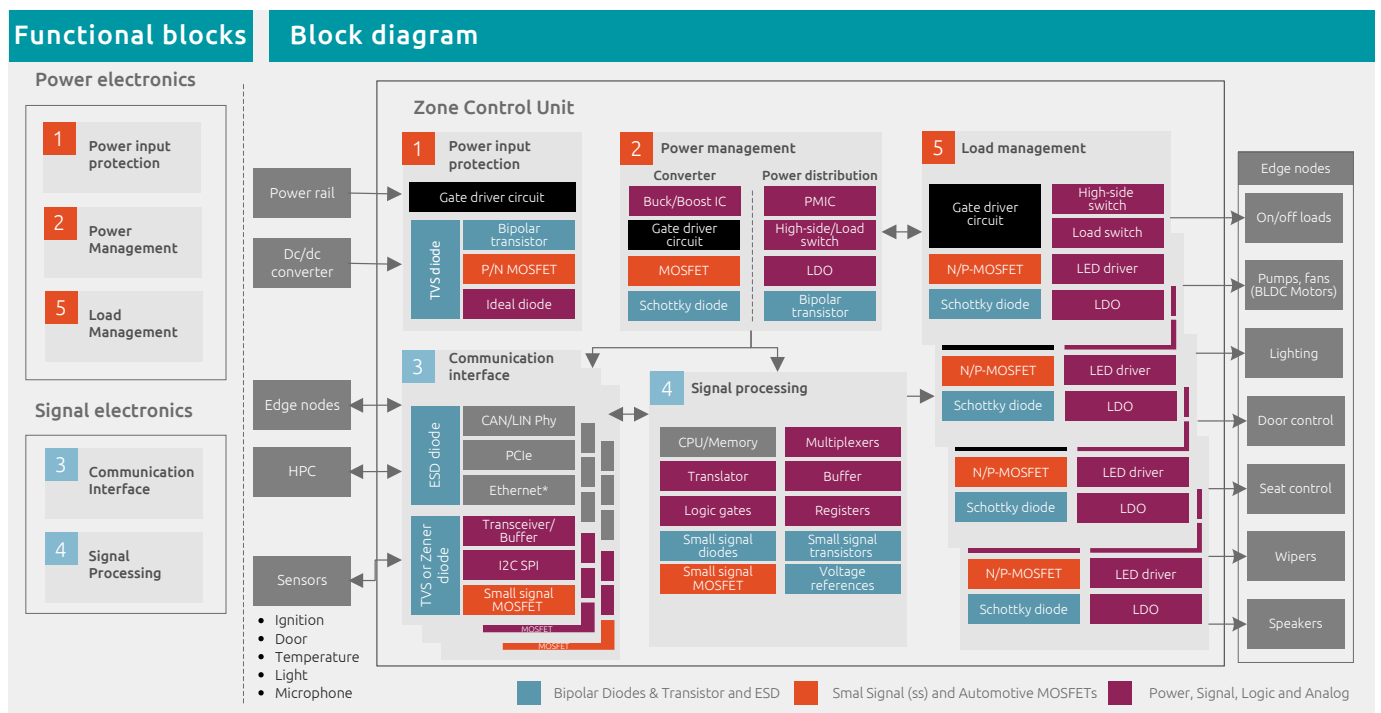

Fig. 1 Zone Control Unit internal electronics block diagram

As the main function is distribution of power and communications to the local actuators, the corresponding blocks appear multiple times.

1 The Power Input Protection block can take up substantial size and large power devices. Besides protecting the rest of the circuit from power surges it can also interconnect various energy supply sources like the batteries and dc/dc converter. It is important to protect the supplies in case the other collapses. It can also appear in several voltage levels like 12 V and 48 V in case the vehicle contains both power nets.

2 The Power Management block contains the means for transforming the incoming voltage to a level that is suitable for the rest of the components. The resulting voltage rails are used to fuel the signal processing and communication blocks. In vehicles with 48 V board nets, this is the place to transform the 48 V to 12 V or 16 V to supply legacy actuators. This is done via high power resonant converters, such as the Switched Tank Converter.

3 The Communication Interface block consists of a variety of communication protocols. Some of these could be analog and slow digital inputs towards sensors. Somewhat faster like IVN and ESD towards information rich peripherals such as ADAS cameras and radars. Audio signals can be transmitted to local speakers and received from microphones. Finally, the received information is translated and packed in a fast Ethernet protocol to communicate with other ZCUs and the central High-performance computer. All these information feeds need to have appropriate protection via ESD or TVS diodes, according to the speed and strength of the signal.

4 Finally, the Signal Processing block contains the Controller and Memory blocks. From the Nexperia arsenal logic gates and registers can be used to establish additional layers of logic and safety that are independent of the main controller; small signal discrete devices can be used for conditioning signals from nearby sensors; and multiplexers and analog switches to increase the digital and analog input channels of the controller.

In this Techbook the Communication Interface block is described in more detail. The challenges a designer might face are addressed with a proposal of appropriate devices and their design in procedures.

2. Design challenges and solutions

The Communication Interface block protects the Signal Processing block (with sensitive and central components like CPU, SOC and memory ICs) from glitches coming from external data connection to other ECUs or signal connections coming from external sensors. The main means for achieving this are ESD diodes. However, protection can be also realised via Zener diodes. The data lines are further adapted to the Signal Processing block via buffers and translators, while the signal lines can be conditioned via signal level discrete devices (MOSFETs, BJTs and diodes) as well as analog switches.

2.1. Protecting data lines from external voltage surges and bursts

All of the ECUs in a car are connected via a host of communication protocols. Some might be end nodes, requiring only one communication interface (be it a fast one or slower one) or they can serve as a hub or communication gateway to collect a number of communication lines and process the information or simply repackage the data and forward it to higher level data processors as the vehicle central computer. All of these communication lines are prone to various overvoltages, either induced, injected via contact to a high voltage potential object (ESD) or caused by a malfunction. ESD devices can protect from short discharges.

ESD devices are tested in combination with the appropriate transceiver (CAN, LIN, FlexRay). Their role is to ensure the network's ESD robustness and protect the transceivers. To pass the test of immunity for RF disturbances, a higher voltage is needed to activate the device. However, a low clamping voltage is crucial for ESD protection performance. Thirdly, as communication lines can be connected to the car battery, transient events, causing disturbances like 28 V for 1 second also need to be survived. Therefore, exact stand-off voltage (V_{RWM}) and low dynamic resistance are key to a good ESD protection device.

Other requirements like the maximal device capacitance and matching of the capacitances of both lines are set by the system owner or external circumstances like the required communication speed and length of communication lines, number of communication nodes etc. For more details, check out [AN11882](#) or [Nexperia handbook on ESD protection](#).

Nexperia Solution

ESD devices serve predominantly to protect data lines [[ESD Automotive Application Guide](#)]. Because of their low capacitances, they enable high data rates to be communicated. Except for the power absorbing capacity of the device, care should be taken for adequate breakdown voltage and dynamic resistance of the device (see Fig. 2 for more selection criteria). If the latter two are high, in case of a large surge event, the current flowing through the device can make the clamping voltage too high for the protected circuit. For a thorough overview of protection concepts with ESD devices, refer to [Nexperia's ESD handbook](#).

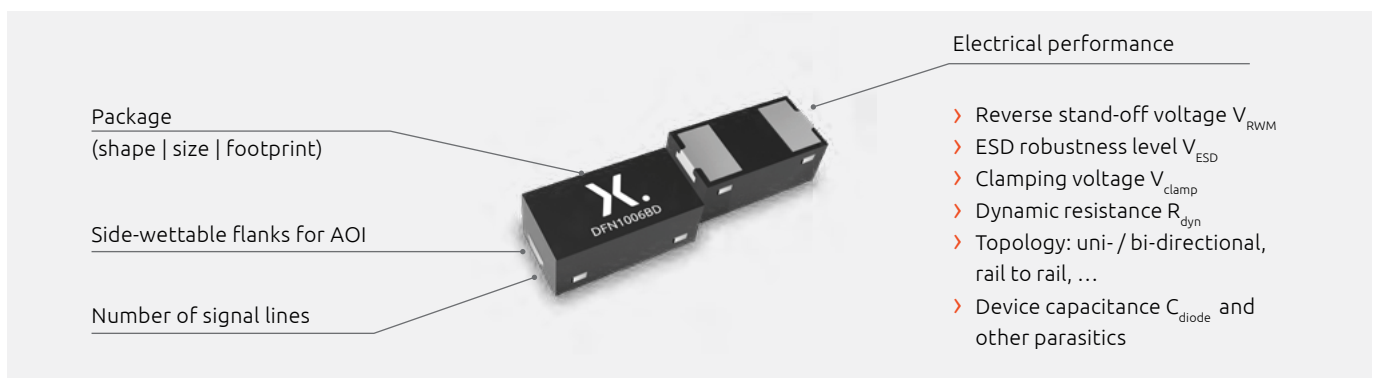

Fig. 2 ESD devices selection criteria.

New vehicle architectures tend to appear in connection with a 48 V battery and board net on newly introduced HEV and BEVs. Nexperia's newly introduced 48 V board net ESD devices address this challenge and can be seen in Table I. Products are available with three different standoff voltage rates: 54 V, 60 V and 72 V; defined in accordance with ISO21780, that contains the 48 V board net specification. Each of the three is divided into two different capacitance classes, with both being very low values, down to 3.4 pF. The low capacitance means that the devices can be used in very high-speed communication lines: CANFD, or CAN SIC. Despite this, the lowest ESD voltage capability of the devices is 15 kV, which addresses all the market requirements.

Product name	Package	V_{RWM} [V]	$C_{D\ max}$ [pF]	I_{PPM} [A]	$V_{BR\ min}$ [V]	$V_{BR\ max}$ [V]	$V_{cl@16A\ TLP}$ [V]	$V_{cl@IPPM\ 8/20\mu s}$ [V]	V_{ESD} [kV]	Board-net [V]
PESD2CANFD54LT-Q	SOT23	54	6	4	56	76	71	73	30	48
PESD2CANFD54VT-Q		54	3.6	2.8	56	76	89	74	17	
PESD2CANFD60LT-Q		60	6	4	62	82	79	77	24	
PESD2CANFD60VT-Q		60	3.6	2.6	62	82	105	78	17	
PESD2CANFD72LT-Q		72	5.4	3	74	94	104	94	20	
PESD2CANFD72VT-Q		72	3.4	1.9	74	94	120	93	15	

Table I 48 V board-net ESD protection

To cover surge capabilities of historical devices in larger packages and for slower communication, Nexperia has introduced high surge robustness devices, shown in Table II.

Device	Package	V_{RWM} [V]	$C_{D\ max}$ [pF]	I_{PPM} [A]	$V_{BR\ min}$ [V]
PESD2CAN24T-Q	SOT23	24	12	5.3	30
PESD2CAN24LT-Q	SOT23	24	25	9	30
PESD2CAN24XLT-Q	SOT23	24	33	12	30

Table II High surge robustness ESD devices

For the protection of the connection of the Ethernet loop the protection diagram in Fig. 3 can be used. The OPEN Alliance proposes two possible external ESD protection devices. As shown in Fig. 3, one can be placed at the connector (ESD_1, focus on high surge immunity) and one at the PHY interface (ESD_2, focus on low capacitance). The specification allows to use of none, one, or both devices to achieve the desired ESD robustness in Ethernet applications [AN90039]. In practice, most solutions opt for the device in position ESD_1. Please find suggested devices for both positions in the device list section.

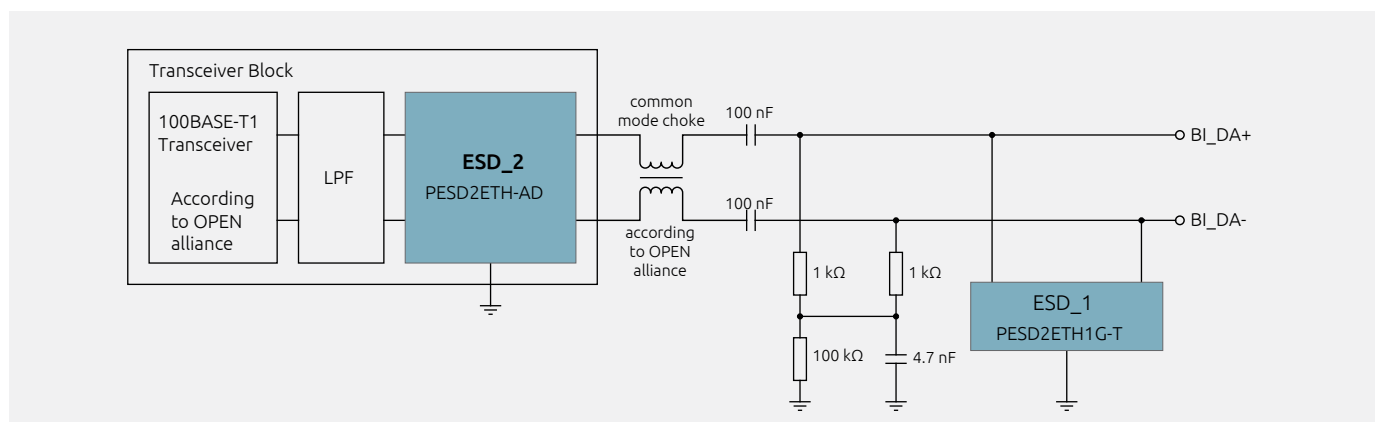
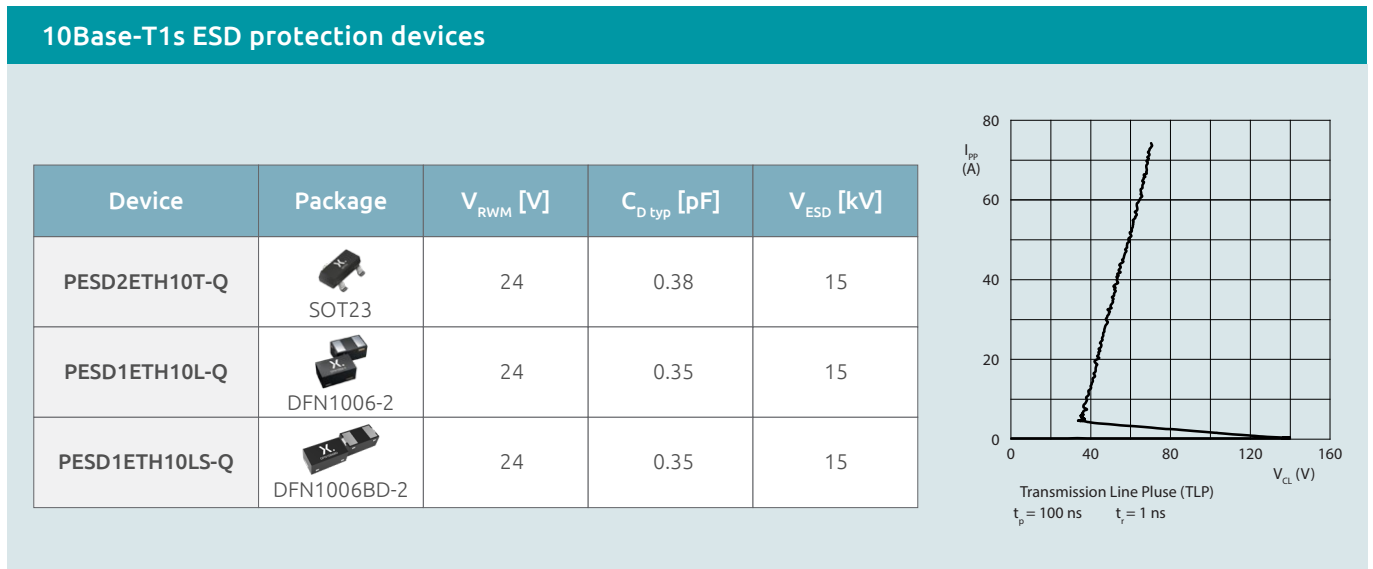

Fig. 3 Interface topology for 10/100/1000BASE-T1 according to OPEN Alliance with placement of ESD protection at the connector and as part of the transceiver block

For 10Base-T1s Ethernet protocol Nexperia ESD protection devices were the first to be approved by the OPEN alliance. They have a V_{RWM} over 75 V which means that they are suitable for 12 V, 24 V and 48 V board nets. The devices are also suitable for protection of 100Base-T1 and 1000Base-T1 Ethernet, which makes them quite an all-rounders.

A further feature of these devices is the very low capacitance for smooth data transmission while retaining the OPEN alliance requirement of 15 kV ESD robustness. Low capacitance is also an enabler for driving high number of parallel nodes of 10Base-T1s. Designs can reach over 20 parallel nodes and the available capacitance budget, dictated by the output strength of the PHY, is very limited. A notable package for these devices is the DFN1006, measuring 1x0.6 mm.



When it comes to higher speed Ethernet protections there are two possibilities for the placement of the protection ESD device, as shown in Fig. 4. In this case the more popular option is Option 2, which is now placed between the common mode choke and the decoupling capacitors rather than next to the PHY. There is no official guidance for protecting these devices and the common mode choke itself is optional. Nexperia devices for both positions are suggested as well.

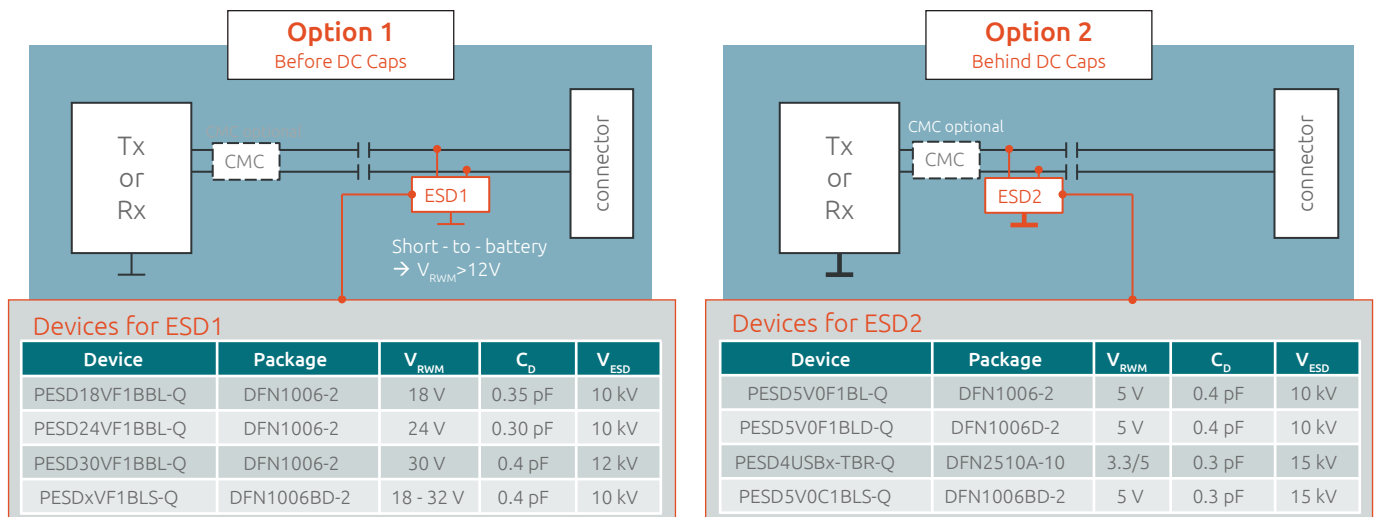

Fig. 4 MGBase-T1 Ethernet ESD protection schematics and devices proposed

As the speed of the main communication loops in the car increases the requirement is shifting towards using option 2 from Fig. 4. This applies to not only Ethernet but ASA (Automotive Serdes Alliance) protocols, infotainment (USB, HDMI etc.) and automotive video links, as well. More devices in DSN0603 are shown in Table III. It can be seen that the typical capacitance for the first device is 0.08 pF with almost 40 GHz bandwidth, which is considered industry leading at the time of writing.

Product name	Package	V _{RWM} [V]	C _D [pF]	I _{PPM} [A]	V _{ESD} [kV]	F _{-3dB} [Ghz]
PESD5V0R1BBSF-Q	SOD962	5	0.08	1	6	>38
PESD5V0R1BDSF-Q	SOD962	5	0.1	4.8	12	>18
PESD5V5C1BBSF-Q	SOD962	5	0.26	8.1	15	>23

Table III DSN0603 chip scale protection devices

2.2. Adapting signals to the processor input specifications

Adapting input and interface signals to a processor’s input specifications is a critical aspect of reliable system design. Processors are designed to operate within well-defined electrical limits—such as voltage levels, current, timing, and logic thresholds—and any external signal must conform to these constraints to ensure correct operation and long-term reliability. Signals originating from sensors, user interfaces, communication buses, or other integrated circuits often differ significantly in amplitude, impedance, or signaling standard, making some form of conditioning or adaptation essential before they reach the processor. Communication standards like UART, SPI, I²C, CAN, or Ethernet each impose specific electrical and timing requirements that must align with the processor’s capabilities.

One of the most common adaptation tasks is voltage level matching. External signals may operate at higher or lower voltages than the processor’s I/O pins can tolerate, requiring level shifters, resistor dividers, or buffer circuits to translate between domains. In addition to protecting the processor from overvoltage or negative transients, proper level adaptation ensures that logic-high and logic-low levels are interpreted correctly according to the processor’s input threshold specifications. This is especially important in mixed-voltage systems or when interfacing legacy components with modern low-voltage processors.

Another key consideration is signal conditioning and integrity. Real-world signals often contain noise, slow edges, or ringing that can lead to false triggering or timing violations at the processor input. Techniques such as filtering, hysteresis (for example, using Schmitt-trigger inputs), termination, and impedance matching help shape signals so they meet the processor’s rise/fall time, noise margin, and timing requirements.

Table IV provides an overview of some of the voltage translation devices recommended for the most common interfaces, in order of increasing bit count.

Interface	Recommended Products		
	3.6 V Maximum	5.5 V Maximum	
1-Bit GPIO, Clock Signal FET Replacement	74AVC1T45, 74AUP1T34	74LVC1T45, 74LV1T34, NXU0101, AXP1T34	1-bit
2-Bit GPIO	74AVC2T245	74LVC2T45, NXU0102	2-bit
2-Pin JTAG/UART	74AVC2T45	74LVC2T45, NXU0202	
I ² C	NCA9306, TXS0102, NCA970x	NCA9306, NXS0102	
MDIO / SMBus / PMBus	NXS0102, LSF0102	NXS0102, LSF0102	3-bit
SIM- Card	NXT4557	NA	
4-Bit GPIO	74AVC4T245, 74AVC4T774, 74AVC4T3144, NXU0104	NXS0104, NXB0104, LSF0204, LVC4T3144, NXU0104	4-bit
UART	74AVC4T245, NXU0204	NXB0104, NXU0204	
SPI	74AVC4T774, NXB0104, NXU0304	NXB0104, 74LVC4T3144, NXU0304	
JTAG / I ² S / PCM	74AVC4T774, NXB0104	NXB0104	
HDMI	NXS0104	NXS0104	6-bit
SDIO/SD3.0/MMC	NXS0506	NA	
Quad-SPI	NXB0106	NXB0106	
8-Bit GPIO	74AVC8T245	74LVC8T245, 74LVC4245A, 74AXP8T245	8-bit

Table IV Voltage level translators suggested for various communication interfaces

2.3. Using digital isolation for additional safety measure

In automotive environments it is of paramount importance to safely bridge noisy, high-energy domains (12 V/24 V/48 V high power switching converters or motor drives, HV traction batteries and motor inverters) with low voltage controllers while maintaining signal integrity, EMC compliance, and functional safety. One bulletproof way to achieve this is to use digital isolators.

Digital isolators provide galvanic isolation breaking ground loops and blocking hazardous common mode voltages so that microcontrollers can interface to sensors, actuators, and communication nodes without exposure to load dump, ground bounce, or HV transients. Compared to optocouplers, modern digital isolators (capacitive, inductive/magnetic, or RF coupled) offer higher data rates, lower power, tighter timing, better aging stability, and significantly higher CMTI (common mode transient immunity), which is crucial when dv/dt events in motor drives and DC/DC converters can exceed tens of $kV/\mu s$.

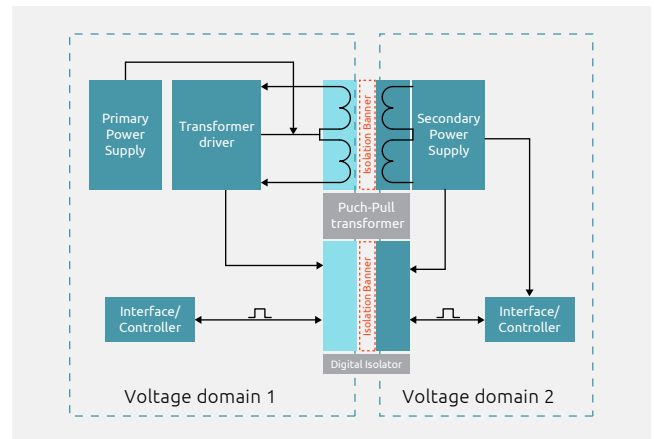
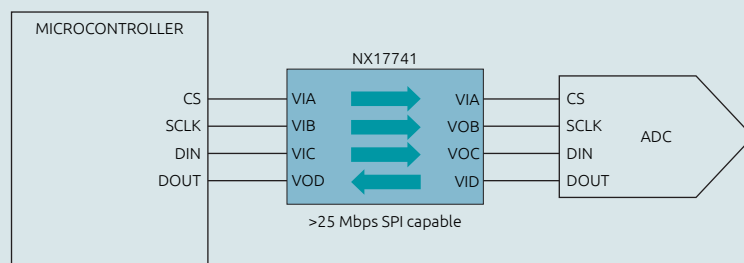

Fig. 5 Digital insulator with two isolated power supply domains

Key specifications to consider begin with the isolation barrier itself: working voltage and surge capability, creepage/clearance distances appropriate for the installation's pollution degree, and qualification against automotive standards. Safety certifications like UL 1577 and VDE 0884-11 help demonstrate barrier integrity and lifetime. In EV/HEV systems—where 400 V or 800 V battery packs interface with low voltage ECUs reinforced isolation may be necessary to meet ISO 26262 safety goals and system partitioning. High CMTI (e.g., $\geq 100 kV/\mu s$) ensures the isolator won't mis toggle when exposed to inverter edges, while adequate ESD and transient robustness support immunity to ISO 10605 and ISO 7637 2 events.

The isolator itself breaks the data path, but isolated power must also be implemented for the remote side (Fig. 5) commonly via an isolated DC/DC converter (flyback, push pull, or transformer driver modules). Converter switching nodes need to be physically separated from the isolator to reduce capacitive coupling across the barrier. Common mode emissions need to be managed with careful layout, controlled return paths, and, where appropriate, common mode chokes on cables. Attention is needed with the isolator's channel-to-channel crosstalk and spread-spectrum or edge rate control can be considered to balance EMI against timing requirements.

Suggested Nexperia Reinforced 6/4/2-Channel Digital Isolators NX177xx-Q100



- > Highly reliable, reinforced, SiO₂- based, isolation barrier
 - > Isolation rating (V_{ISO}): 5,000 V_{RMS}
 - > Working voltage (V_{IOWM}): 1,500 V_{RMS}
 - > Surge immunity: 10,000 V
- > Data rate: DC to 200 Mbps
- > Power supply voltage: 2.25 V to 5.5 V
- > Robust electromagnetic compatibility (EMC)
 - > System-level ESD, EFT and surge
 - > Low emissions
- > ActiveX CMTI: 250 kV/ μs (industry highest)
- > Industry lowest propagation delay: <10 ns
- > Fail-safe IO allows any order power-up
- > Pin-to-pin, drop-in replacement for popular digital isolators
- > Wide temperature range: -55°C to 125°C
- > AEC-Q100 qualified
- > VDE, UL, CQC, CSA safety certifications available

Suggested Nexperia Low-noise 1.2 A transformer driver for isolated power supplies NXF650x(A/B)-Q100

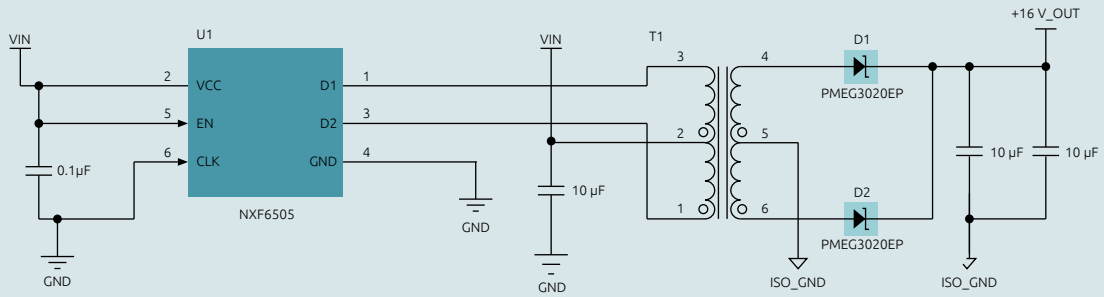

- > Push-pull driver for transformers
- > Wide input voltage range: 2.25 V to 5.5 V
- > High output drive: 1.2 A at 5 V supply
- > Low RON 0.2 Ω max at 5 V supply
- > Robust break-before-make (BBM)
- > Fail-safe IO prevents back-powering of local supply
- > Spread-spectrum clocking for ultra-low radiated emissions
- > Over current protection with hiccup mode
- > Soft-start : 5 ms
- > Support thermal shutdown
- > Pin-to-pin drop-in upgrade
- > Ability to use external clock to synchronize multiple transformer drivers for high current applications
- > Wide temperature range: -55°C to 125°C
- > AEC-Q100 qualified

3. Recommended products

Product	Description	Key part numbers
Communication interface		
ESD for CAN and IVN	SOT package, 3-17 pF, 30 kV protection for 12 V board net	PESD2IVN27T-Q , PESD2IVN27U-Q , PESD2CANFD24UT-Q , PESD2CANFD24UU-Q
	DFN package, 3.5-10 pF, 30 kV protection for 12 V board net	PESD2CANFD24UQB-Q , PESD2CANFD24UQC-Q
	SOT package, 3.9-10 pF, 30 kV protection for 24 V board net	PESD2CANFD36UT-Q , PESD2CANFD36UU-Q
	DFN package, 3.5-10 pF, 30 kV protection for 24 V board net	PESD2CANFD36LQC-Q , PESD2CANFD33UQB-Q , PESD1CANFD24LS-Q
	SOT23, 8 pF, 30 kV protection for 48 V board net	PESD2IVN48T-Q , PESD2CANFD54VT-Q , PESD2CANFD60VT-Q , PESD2CANFD72VT-Q
ESD for Ethernet (ESD_1 from Fig. 3)	SOT23, 1-3 pF, 30 kV protection, 24 V standoff voltage	PESD2ETH100T-Q , PESD2ETH1GXT-Q
	DFN1006 BD-2, 1.2-1.8 pF, 30 kV protection, 24 V standoff voltage	PESD1ETH10L-Q , PESD1ETH10LS-Q , PESD1ETH1GXLS-Q
ESD close to PHY (ESD_2 from Fig. 3)	DFN1006-2, <0.6 pF, >10 kV protection	PESD18VF1BBL-Q , PESD24VF1BBL-Q , PESD30VF1BBL-Q , PESD5V0C1BLS-Q
High speed multimedia ESD protection	SuperSpeed USB 3.2 at 10 Gbps, HDMI, DisplayPort, external Serial Advanced Technology Attachment (eSATA), Low Voltage Differential Signaling (LVDS), and Gigabit Multimedia Serial Link (GMSL) Serializer/Deserializer (SerDes)	PESD4USB3U-TBS , PESD4USB3B-TTS , PESD4USB5U-TTS , PESD4USB5B-TBS

4. References

Nexperia handbooks

[MOSFET and GaN FET application handbook](#)

[ESD Application Handbook](#)

[Bipolar Junction Transistor \(BJT\) Application Handbook](#)

[Diode fundamentals, characteristics and applications](#)

[Logic product features and application insights](#)

Application notes

[AN90003 | LPAK MOSFET thermal design guide](#)

[AN11882 | High|speed interfaces | ESD protection and EMI filtering](#)

Other collaterals

[Brochure | ESD Protection Applications](#)

[Brochure | Nexperia_ESD_Automotive_Application_Guide](#)

[Leaflet | Nexperia_Automotive_Ethernet_leaflet_ESD_Protection_Factsheet](#)

© 2026 Nexperia B.V.

All rights reserved. Reproduction in whole or in part is prohibited without the prior written consent of the copyright owner. The information presented in this document does not form part of any quotation or contract, is believed to be accurate and reliable and may be changed without notice. No liability will be accepted by the publisher for any consequence of its use. Publication thereof does not convey nor imply any license under patent- or other industrial or intellectual property rights.

[nexperia.com](https://www.nexperia.com)

Date of release:

May 2026

